

ALUMERO

AC 2.1
FLAT ROOF S 10+

EN

DATA SHEET

FLAT ROOF S10+ AC 2.1

Your big plus

- + Tested in a wind tunnel
- + Quick and simple mounting thanks to pre-assembled components
- + Low transport costs
- + Optimum module ventilation
- + Water drains off on all sides
- + Main structure made of aluminium/stainless steel
- + No roof penetration necessary
- + Module clamps with integrated earthing pins
- + Light and durable
- + TÜV-certified according to UL 2703

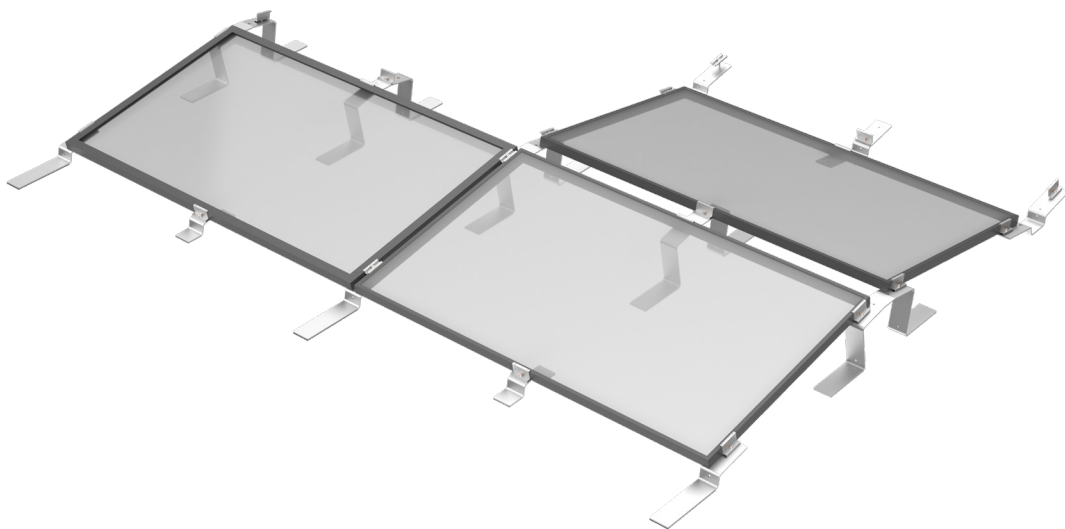

Technical data

Description:	Aerodynamic mounting system for the installation of framed PV modules on flat roofs.
Area of application:	On foil and bitumen roofs with and without thermal insulation under the waterproofing layer as well as on concrete and gravel roofs and green roofs on request
Module dimensions:	950 – 1,150 mm × 1,500 – 2,250 mm (width × length)
Set-up angle:	10°, both sides
Spacing between rows:	Flat roof AC 2.1 S 10+ (8-18° internal shade angle): 464 mm Flat roof AC 2.1 S 10+ (10° internal shade angle): 297 mm
Gap to the roof surface:	approx. 60 mm, may be less on gravel roof
Gap to the roof edge:	1,200 mm (smaller roof edges on request), roof areas F and G in accordance with EN 1991-1-4 can be covered.
Max. building height:	25 m (adaptation to higher buildings on request)
Max. roof pitch:	up to 5° possible without roof anchors, over 5° only with roof anchors
Min. & max. array size:	Min. 1 double row per 2 modules, max. 12 × 8 double rows, 192 modules or 20 × 20 m
Wind load:	Suction-wind load up to 2.4 kN/m ²
Snow load	Compressive load flat roof AC 2.1 S 10+ standard up to 2.4 kN/m ² Compressive load flat roof AC 2.1 S 10+ alpine up to 4.4 kN/m ²
Design / stability	Software-supported on the basis of tests done in a wind tunnel
On-site requirements	Sufficient static load-bearing capacity of the roof structure and the building structural system as well as a sufficient pressure-bearing capacity of the roof construction must be ensured on site. The general conditions of business and warranty apply, as does the user agreement.
Module release	The module release must be obtained from the module manufacturer or taken from the corresponding data sheet.
Components	Module clamps with earthing pin, flat roof clips, wind baffle plates, ballast blocks, ballast trays, roof anchors
Materials	Load-bearing connectors made of aluminium EN AW 6060 T64, module clamps made of aluminium EN AW 6063 T66, bolts made of stainless steel A2-70, wind baffle plates and ballast trays made of steel with aluminium-zinc coating, building protection mat made of polyester fleece



Technical drawings

Flat roof S 10+ – 297 mm

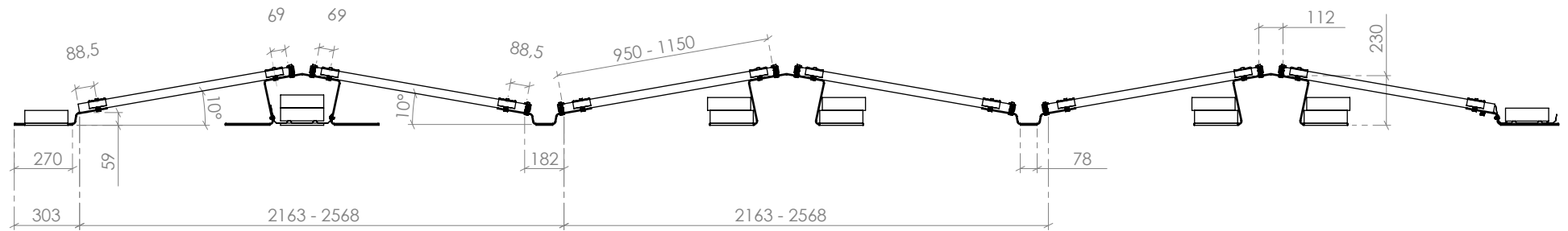

Flat roof S 10+ – 464 mm

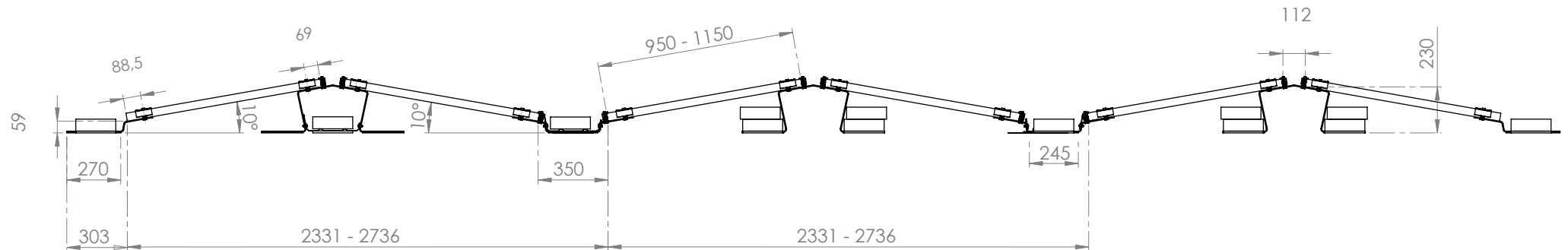

ALUMERO.PRO.TOOL

Project planning in 8 steps

- 1 Master data
- 2 Roof data
- 3 Roof measurement
- 4 PV modules
- 5 Structure
- 6 CAD diagram
- 7 Structural design
- 8 Material list



Component overview

You can find further items in our product catalogue or on our website www.alumerogroup.eu

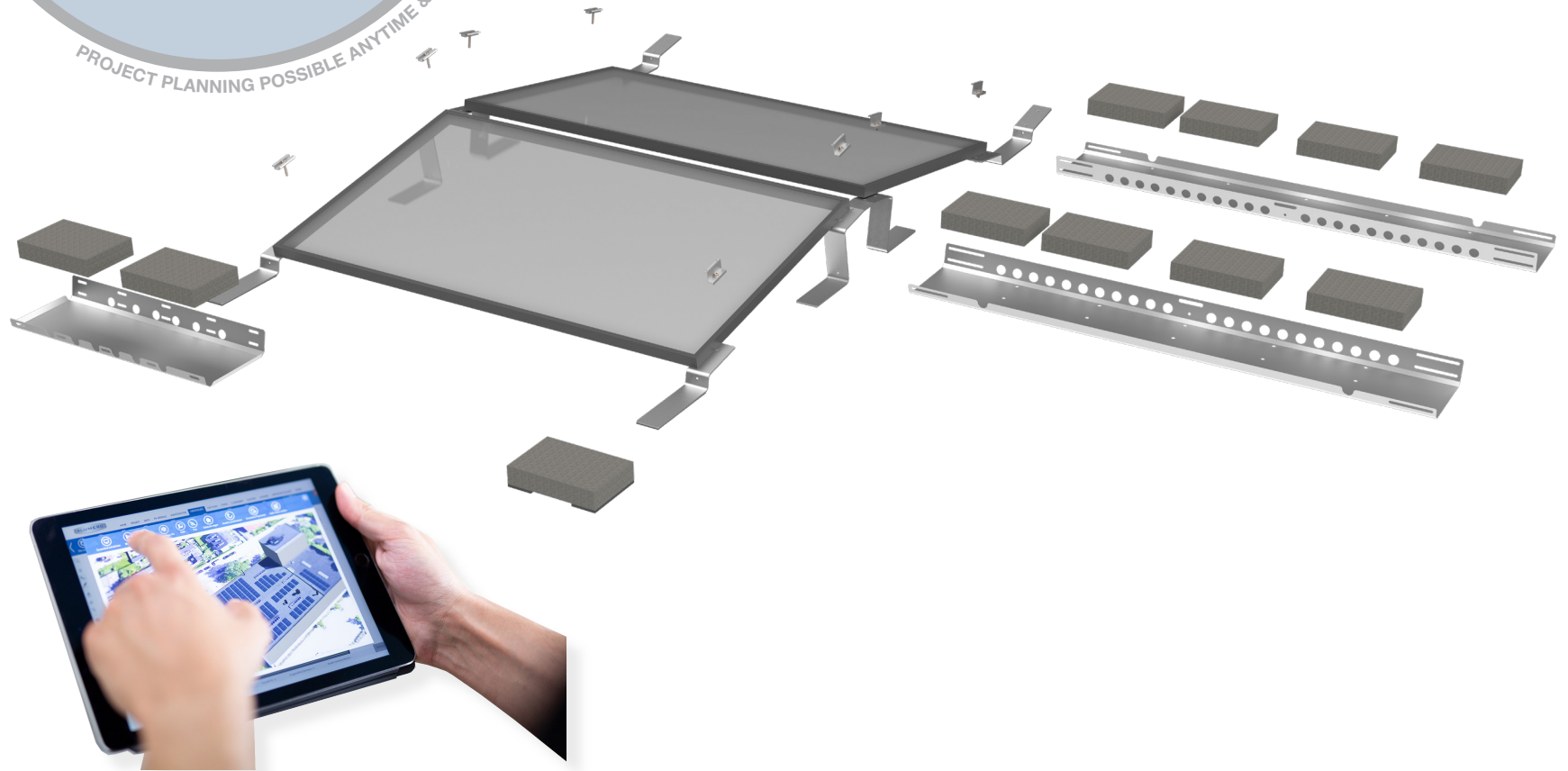

We give our customers the possibility of creating technical, project-related system designs incl. static calculation and project reports using our online software **Alumero.Pro.Tool**.

makes us stronger.