

ALUMERO

FLAT ROOF AC 2.1+

EN

SOLAR MOUNTING INSTRUCTIONS

Before starting mounting, read carefully through the safety notes which you will find at the end of the mounting instructions. Please make sure before you start mounting work that you have the latest version of the mounting instructions available.

The software **ALUMERO.PRO.TOOL** should be used for designing and planning the mounting system. You will find the necessary materials as well as the positions and layout of the individual components in the project report you receive from ALUMERO.PRO.TOOL or from your ALUMERO sales partner. These data have been statically calculated and are extremely important for the safe and perfect function of the system.

The installer of the photovoltaic system must ensure before mounting that the supporting roof construction has been designed for any additional loads which may occur.

These mounting instructions explain the procedures for mounting the ALUMERO AC 2.1 flat roof system, attachment to the supporting roof structure and mounting of the modules.

The ALUMERO flat roof AC 2.1 system has been designed exclusively for accommodating PV modules. Any other use is considered non-intended.

The mounting work may only be carried out by qualified specialists. Work on the roof covering in particular should always be done by a roofer.

If you have any further questions, use ALUMERO's professional and comprehensive consultation service.

TABLE OF CONTENTS

Technical data	P 3
Components	P 4-6
Variants	P 7
Mounting the modules	P 8-16
Mounting the alpine supports	P 17-21
Mounting the ballast system	P 22-29
Roof anchor connection	P 30-32
Equipotential bonding earthing	P 33
Notes Imprint	P 34-37

TECHNICAL DATA

Area of application:	Foil-bitumen roofs as well as gravel and green roofs
Module dimensions:	950 – 1150 mm x 1500 – 2250 mm (width x length)
Module inclination angle:	10° (east-west orientation)
Gap to the roof surface:	approx. 60 mm
Roof pitch:	Up to 5° possible without roof anchors depending on the roof conditions, over 5° only with roof anchors
Wind load:	Suction-wind load up to 2.4 kN/m ²
Snow load:	Standard up to 2.4 kN/m ² , alpine variant up to 4.4 kN/m ²
Standard evidence of safety:	Software-supported on the basis of tests done in a wind tunnel
Roof characteristics:	The static load-bearing capacity of the roof structure and the building structural system as well as a sufficient pressure-bearing capacity of the thermal insulation must be ensured on site.
Material for supporting construction:	Aluminium EN AW 6060; panels made of steel with aluminium-zinc coating; consumables made of stainless steel A2-70; building protection mat made of polyester fleece.

TOOLS REQUIRED

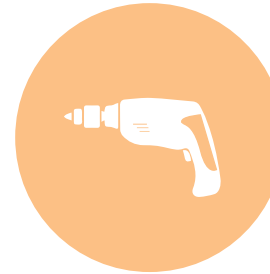

Cordless screwdriver
with bits:
hexagon **A/F 6**



Tape measure

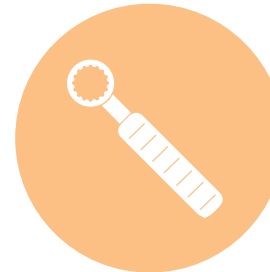

Torque wrench

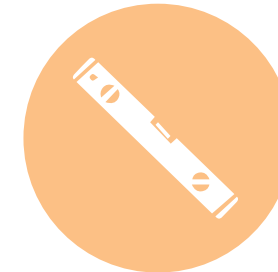

Spirit level

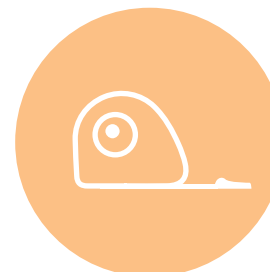

Chalk line

COMPONENTS

AC 2.1+

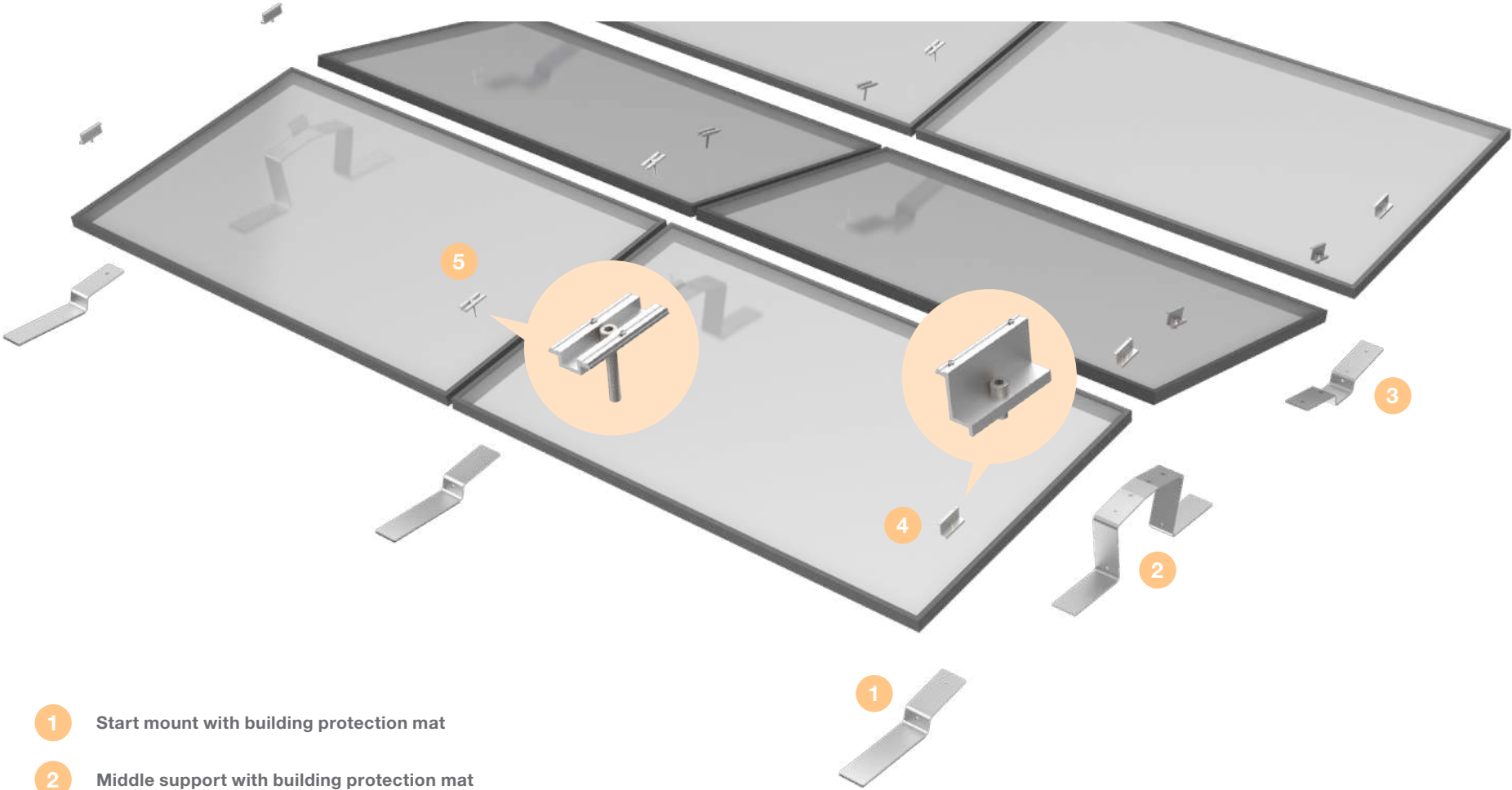

- 1 Start mount with building protection mat
- 2 Middle support with building protection mat
- 3 Connector (long / short) with building protection mat
- 4 End clamp
- 5 Middle clamp AC pre-assembled with pins

COMPONENTS

BALLAST SYSTEM

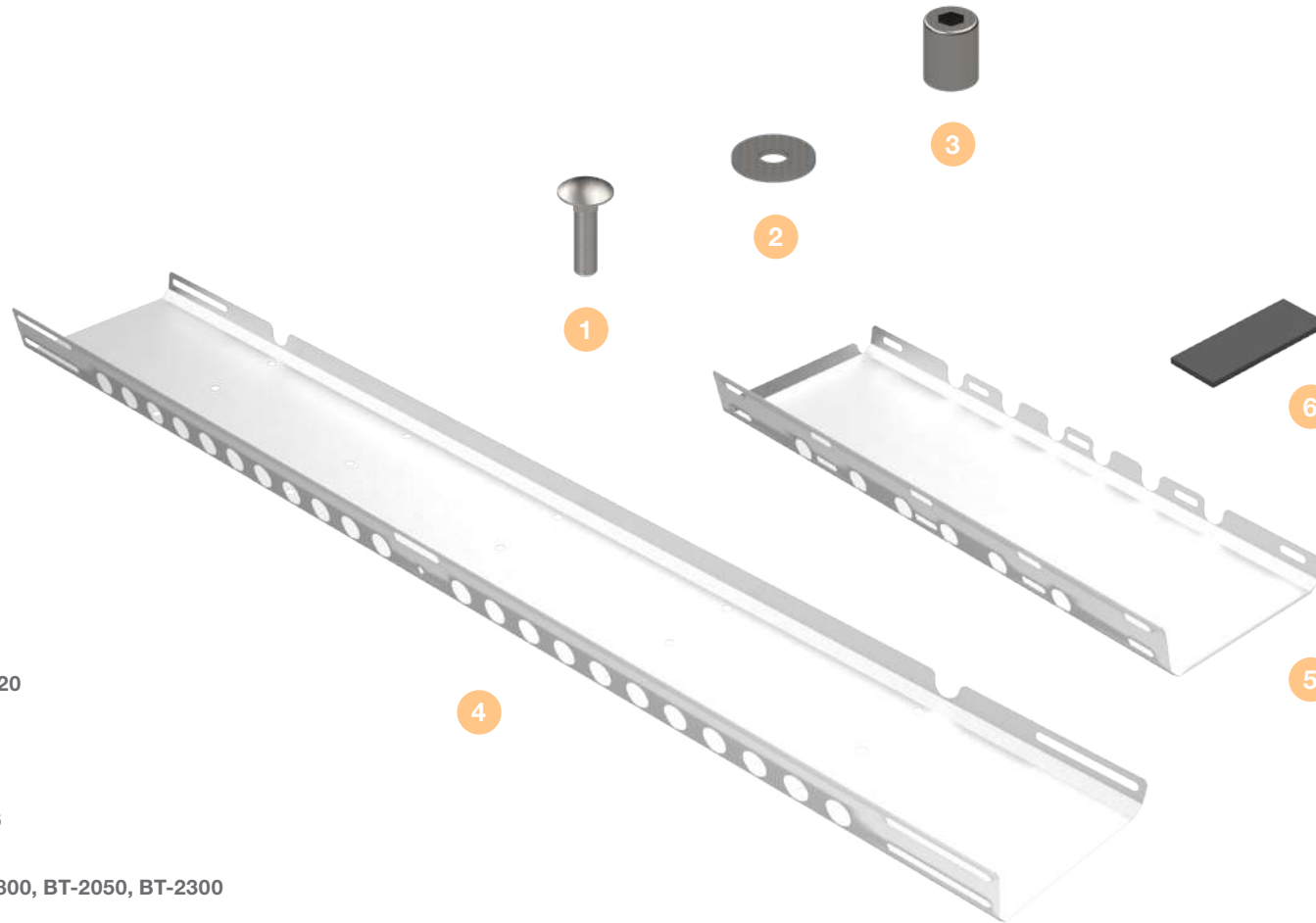

- 1 Cup square bolt, M8x20
- 2 Washer
- 3 Hexagon nut, M8 SW6
- 4 Ballast tray long, BT1800, BT-2050, BT-2300
- 5 Ballast tray short, BT-880
- 6 Building protection mat, PES

COMPONENTS

ALPINE SUPPORTS

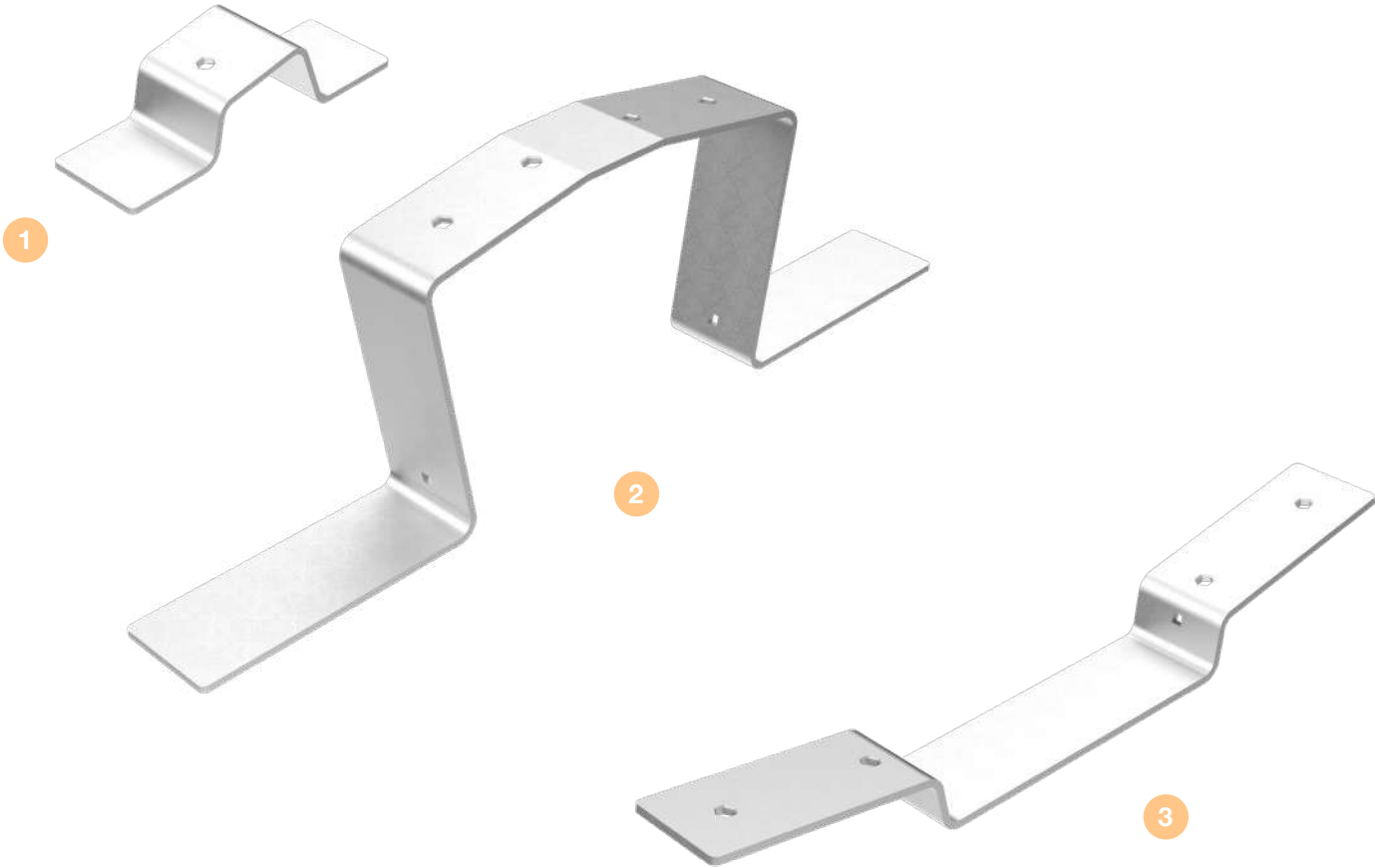

- 1 Alpine support, front, with building protection mat
- 2 Middle support with building protection mat
- 3 Connector (long / short) with building protection mat

VARIANTS

FLAT ROOF AC 2.1+

297 mm gap 10° internal shade angle



FLAT ROOF AC 2.1+

464 mm gap 8° – 18° internal shade angle



MOUNTING

INFORMATION ABOUT MOUNTING ON GRAVEL ROOFS

The planning documents define whether the system is set up directly on the waterproofing or the protective fleece (coefficient of friction 1.5) or freely on the gravel (coefficient of friction 0.3).

Setting up the system on seal or protective fleece

Height of gravel bed: 30 – 60 mm

Since the high punctual load can damage the roof waterproofing, do not set the system up on the gravel with gravel layers up to 60 mm in height.

- » **Remove the gravel carefully near the module array.**
- » **Set the system up directly on the waterproofing or on the protective fleece.**

Use the gravel for ballast in accordance with the ALUMERO.PRO.TOOL report.

Setting up the system on the gravel

Gravel bed 60 – 100 mm and protective fleece (min. 300 g/m²) is available or gravel bed is 100 mm or higher.

- » **Setting up the system on the gravel.**

MOUNTING

PRE-ASSEMBLING THE CLAMPS

» Attach the end or middle clamps to the start mounts, middle supports and connectors as required.

End clamps

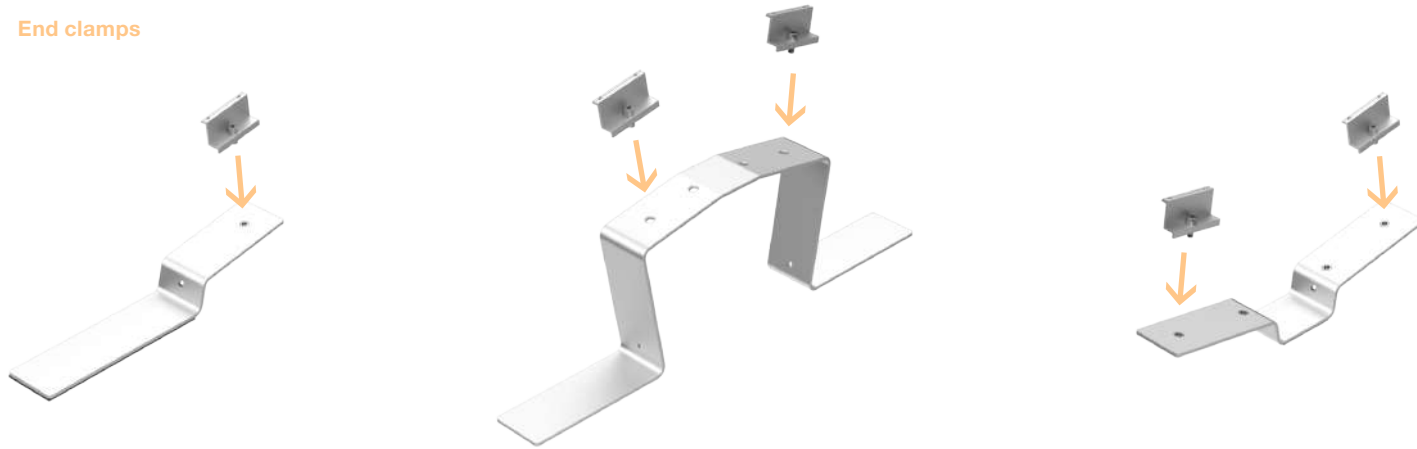

Middle clamps

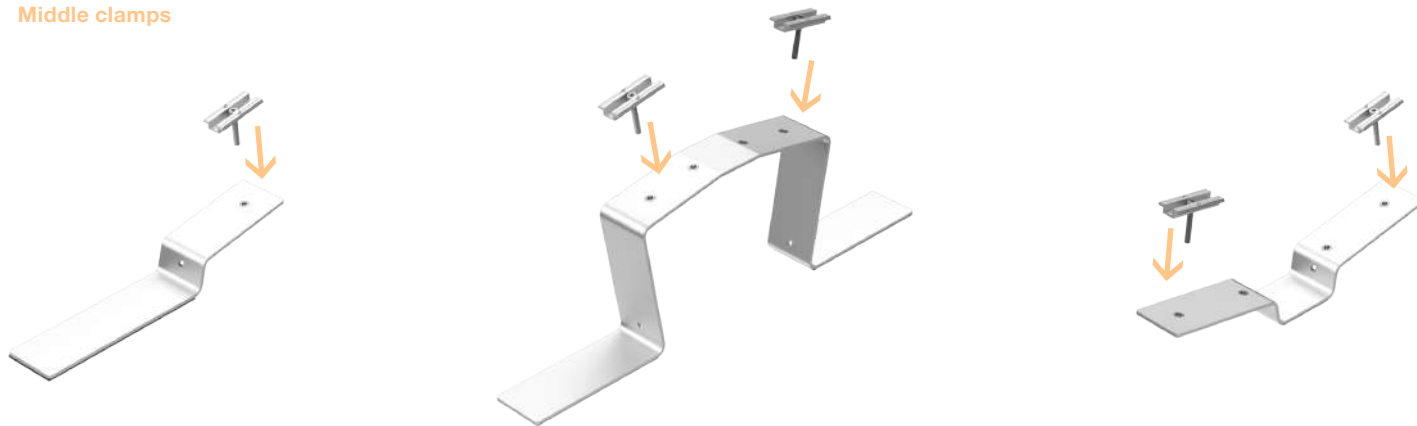

MOUNTING

MEASURE AREA, POSITION COMPONENTS

- » Take the dimensions of the module array from the planning documents.
- » Measure the length of the module array **1** and mark the line.
- » Measure the width of the module array **2** and mark the line.
- » Position the start mounts, middle supports and connectors in the module array **3**.

Edge rows: Position the start mounts, middle supports and connectors with end clamps.

Middle rows: Position the start mounts, middle supports and connectors with middle clamps.

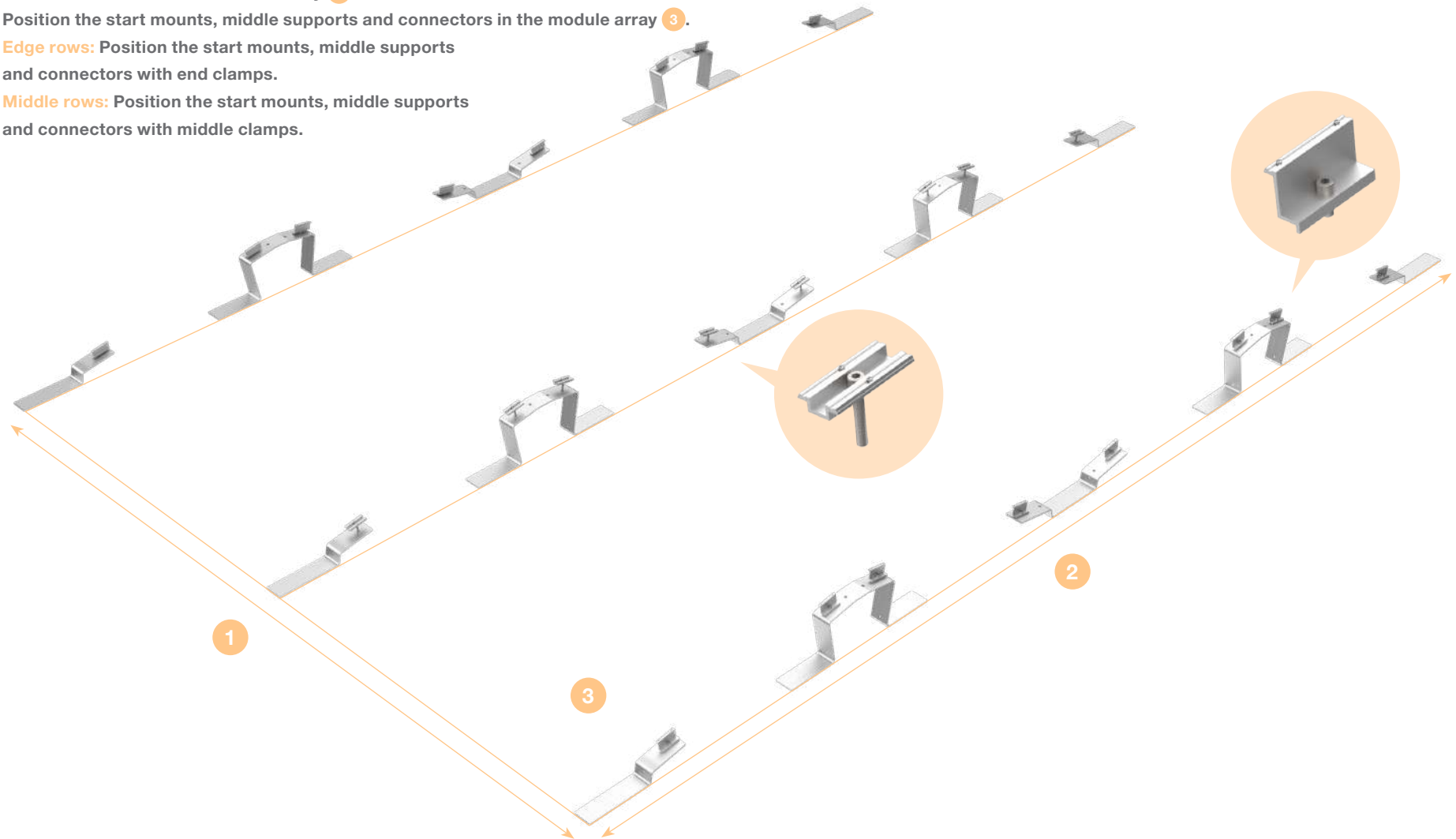

MOUNTING

MOUNTING THE MODULES

Tip: Wire up the modules during mounting.

The cables can be attached to the module using the cable tie clip.

The gap between the clamps is given by the mounts / connectors or the module size.

Mounting the first module row

- » Weigh down the start mounts with ballast blocks **1**.
- » Place the module **2** on the start mounts and middle supports.

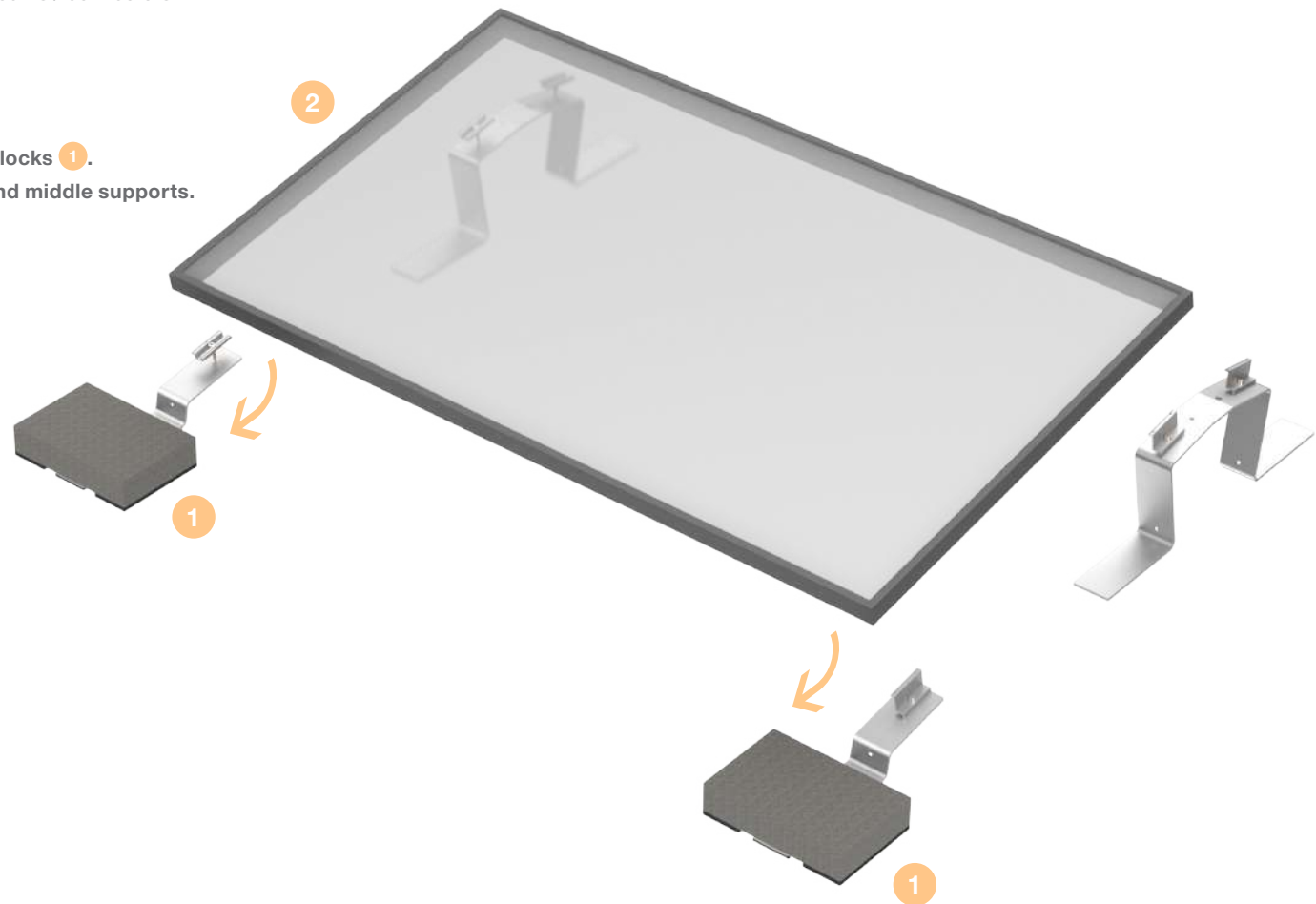

MOUNTING

MOUNTING THE MODULES

- » Align the modules at the notches on the mounts / middle supports.
- » Tighten the screws on the end clamps to 15 Nm.

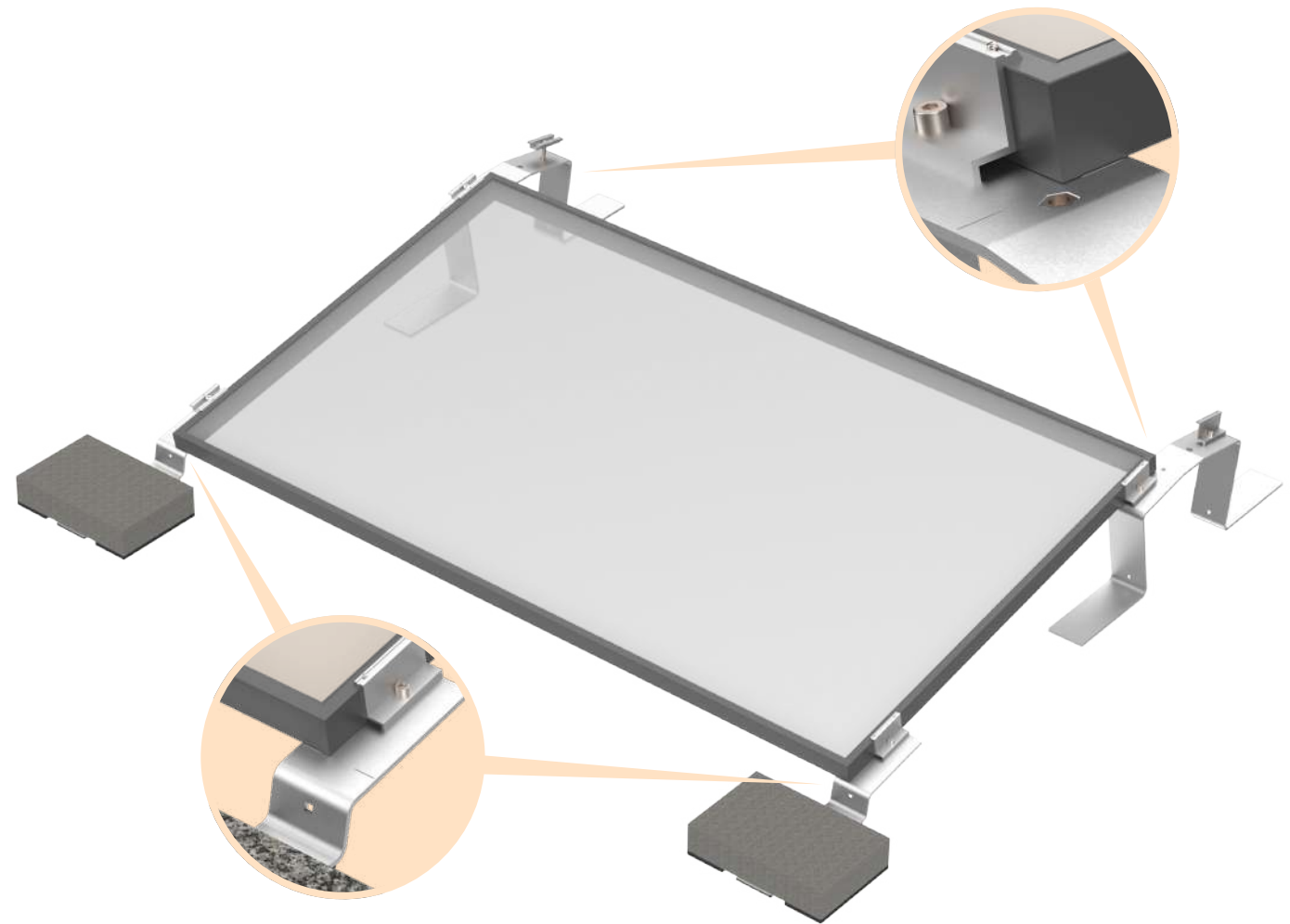

MOUNTING

MOUNTING THE MODULES

- » Position the next module **1**.
- » Tighten the screws at the middle clamps **2** of the previous module to 15 Nm.

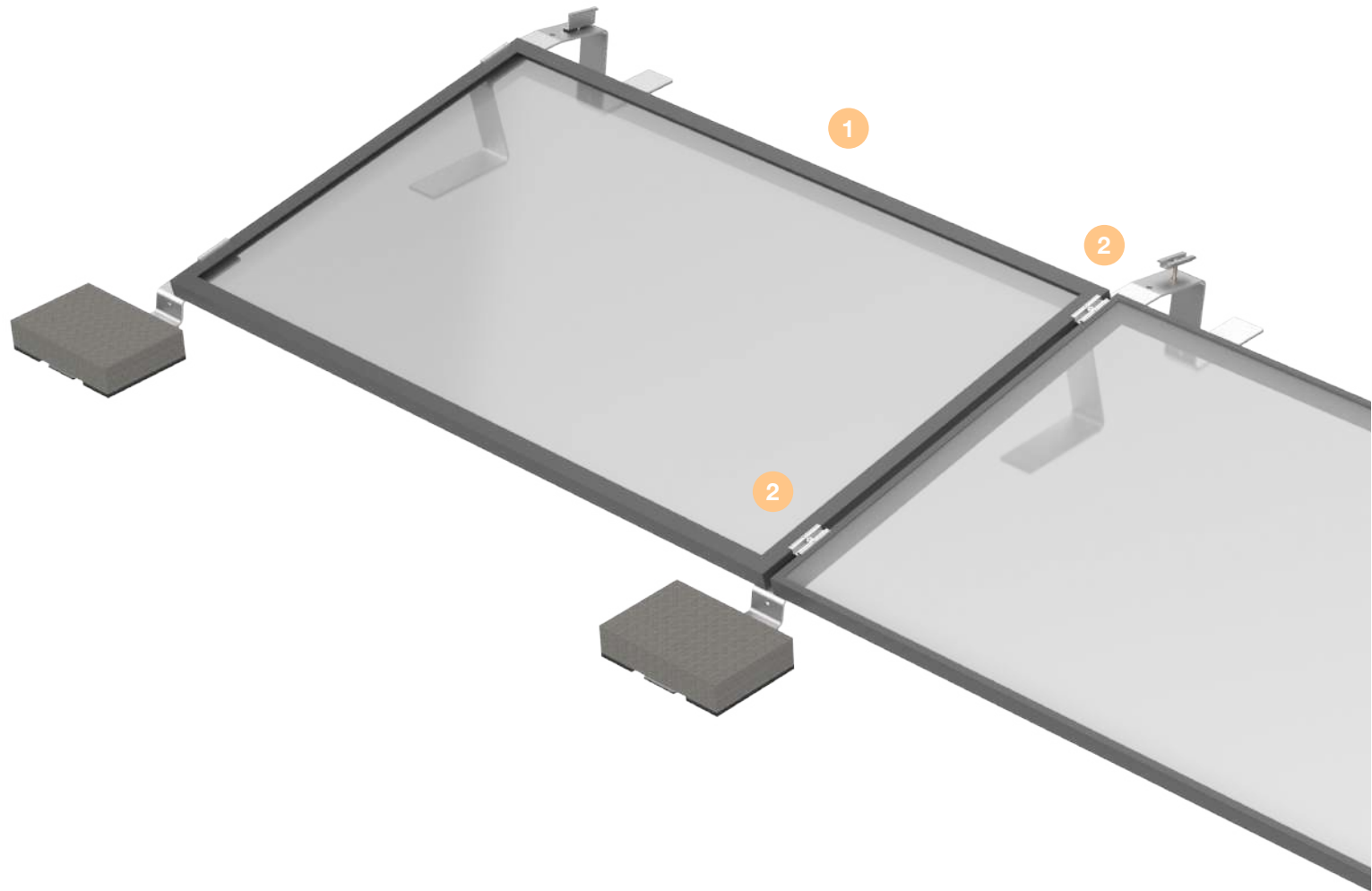

MOUNTING

MOUNTING THE MODULES

- » For a stronger bond, attach a further end clamp on each of the middle supports.
- » Tighten the screws to 15 Nm.
- » Mount further modules in this row in the as described.

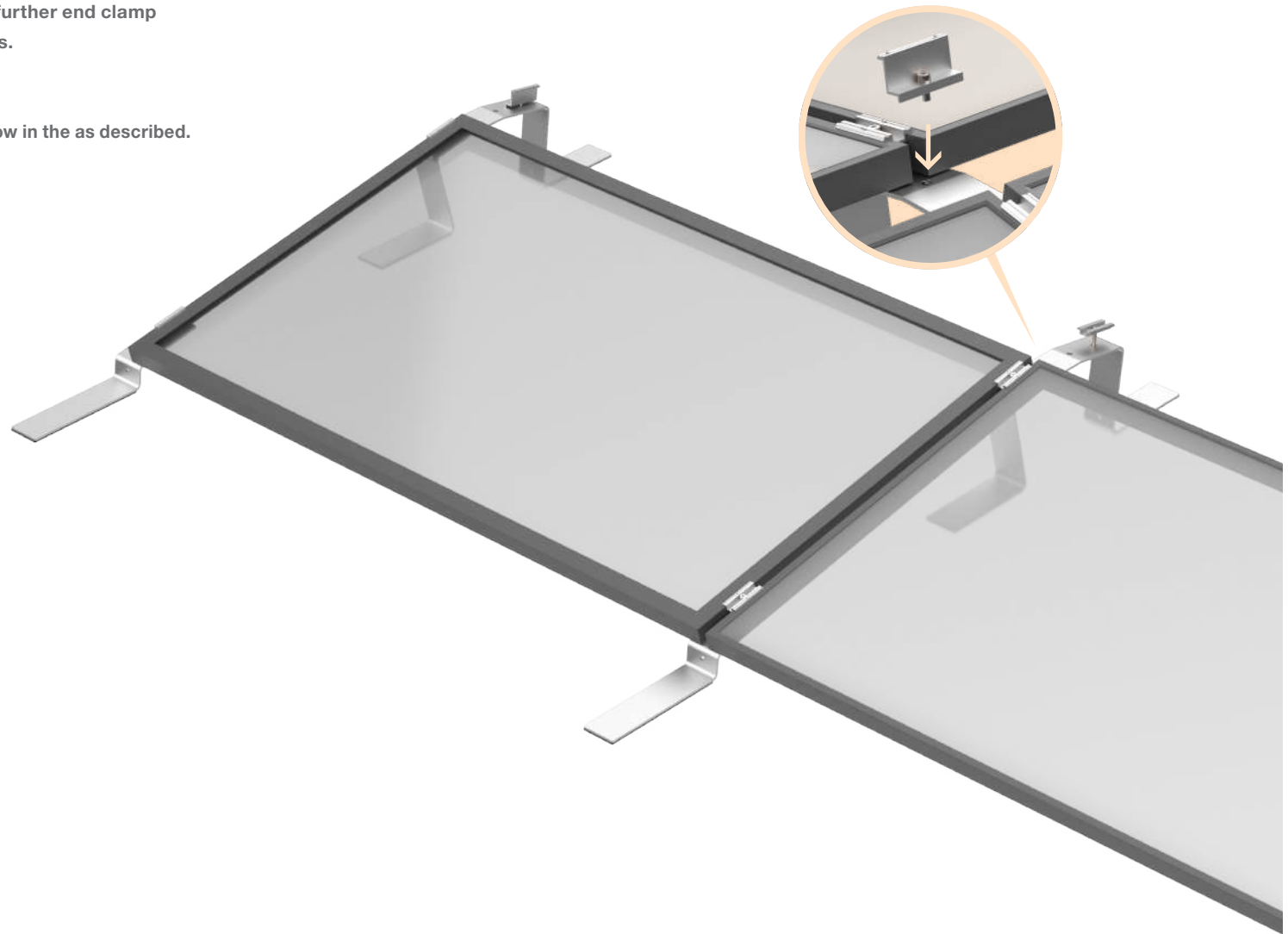

MOUNTING

MOUNTING THE MODULES

Mounting the second module row

- » Place the module **1** on the middle supports and connectors.
- » Align the modules at the notches on the middle supports / connectors.
- » Tighten the screws on the end clamps **2** to 15 Nm.

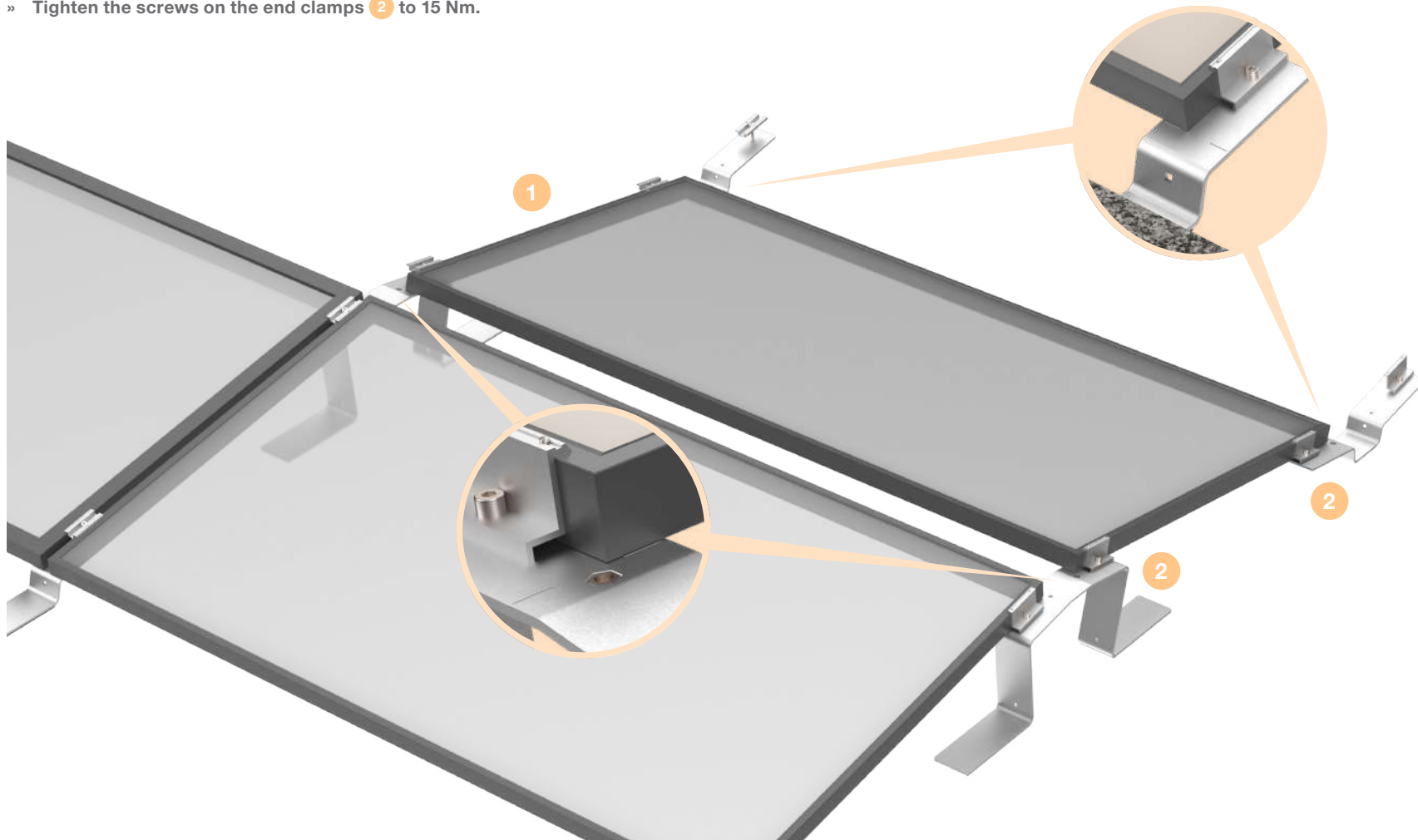

MOUNTING

MOUNTING THE MODULES

- » For a stronger bond, attach a further end clamp at the marked positions on each of the middle supports.
- » Tighten the screws to 15 Nm.

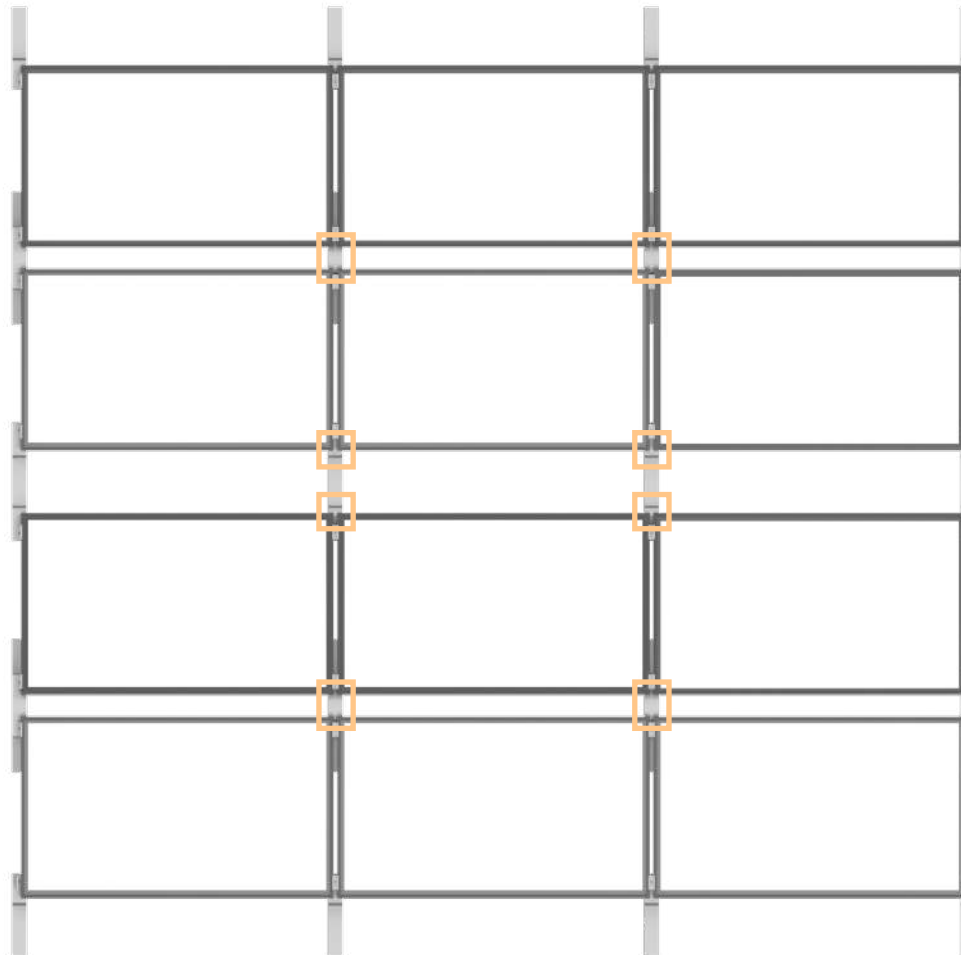

OPTIONAL: MOUNTING ALPINE SUPPORTS

MOUNTING THE MODULES

From a certain snow load, additional supports (alpine supports) are mounted in the middle of the module. The planning documents will indicate whether or not alpine supports are necessary.

Before mounting the alpine supports, make sure that the modules are suitable for increased snow load and clamping in the designated clamping area.

- » Attach end clamps to the front alpine supports **1**, the additional middle supports **2** and connectors **3**.

End clamps

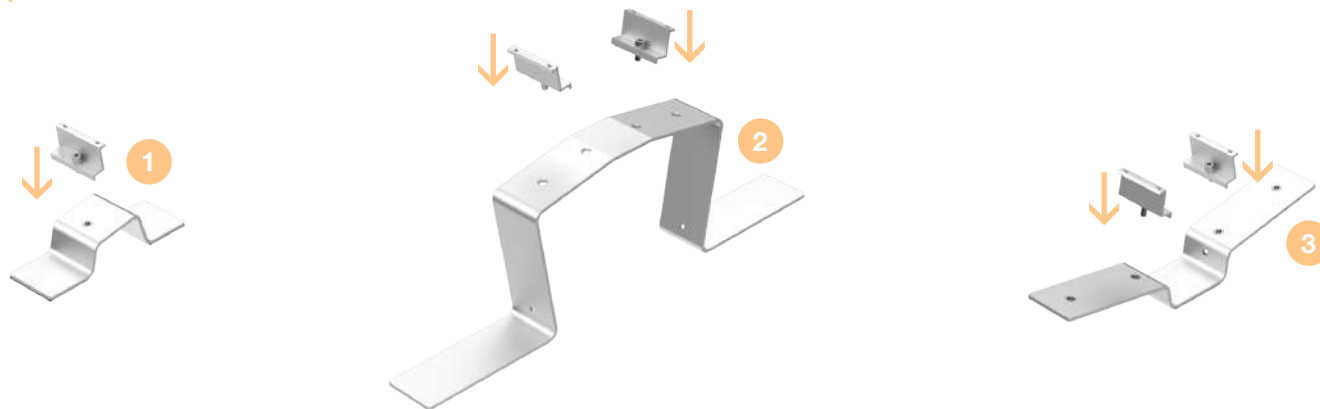

OPTIONAL: MOUNTING ALPINE SUPPORTS

MOUNTING THE MODULES

| The alpine supports are mounted in parallel with the modules.

- » Place one middle support **1** and one connector **2** in the centre of each module.

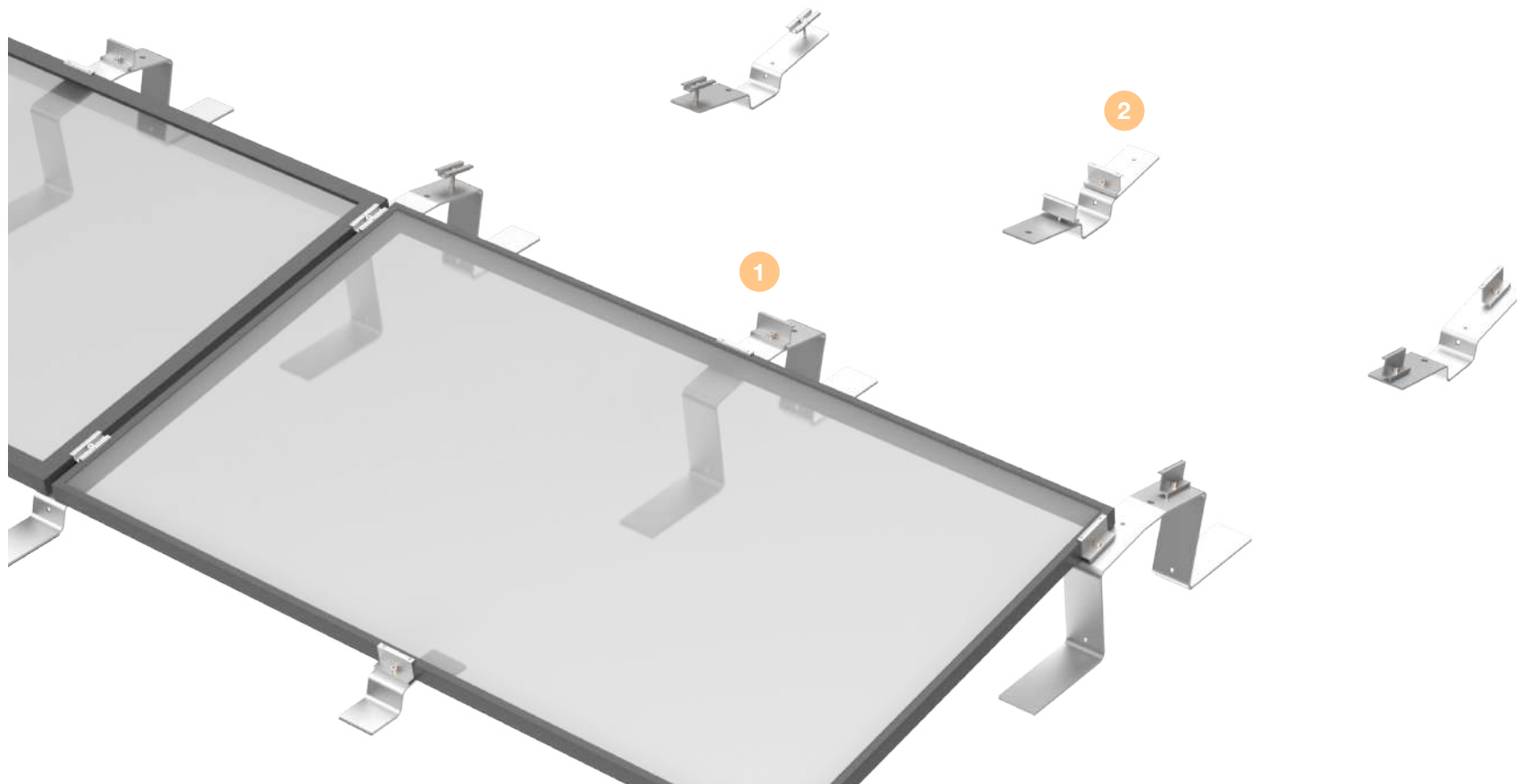

OPTIONAL: MOUNTING ALPINE SUPPORTS

MOUNTING THE MODULES

- » Place the module **1** on the middle supports and connectors.
- » Tighten the screws on the end clamps **2** to 15 Nm each.

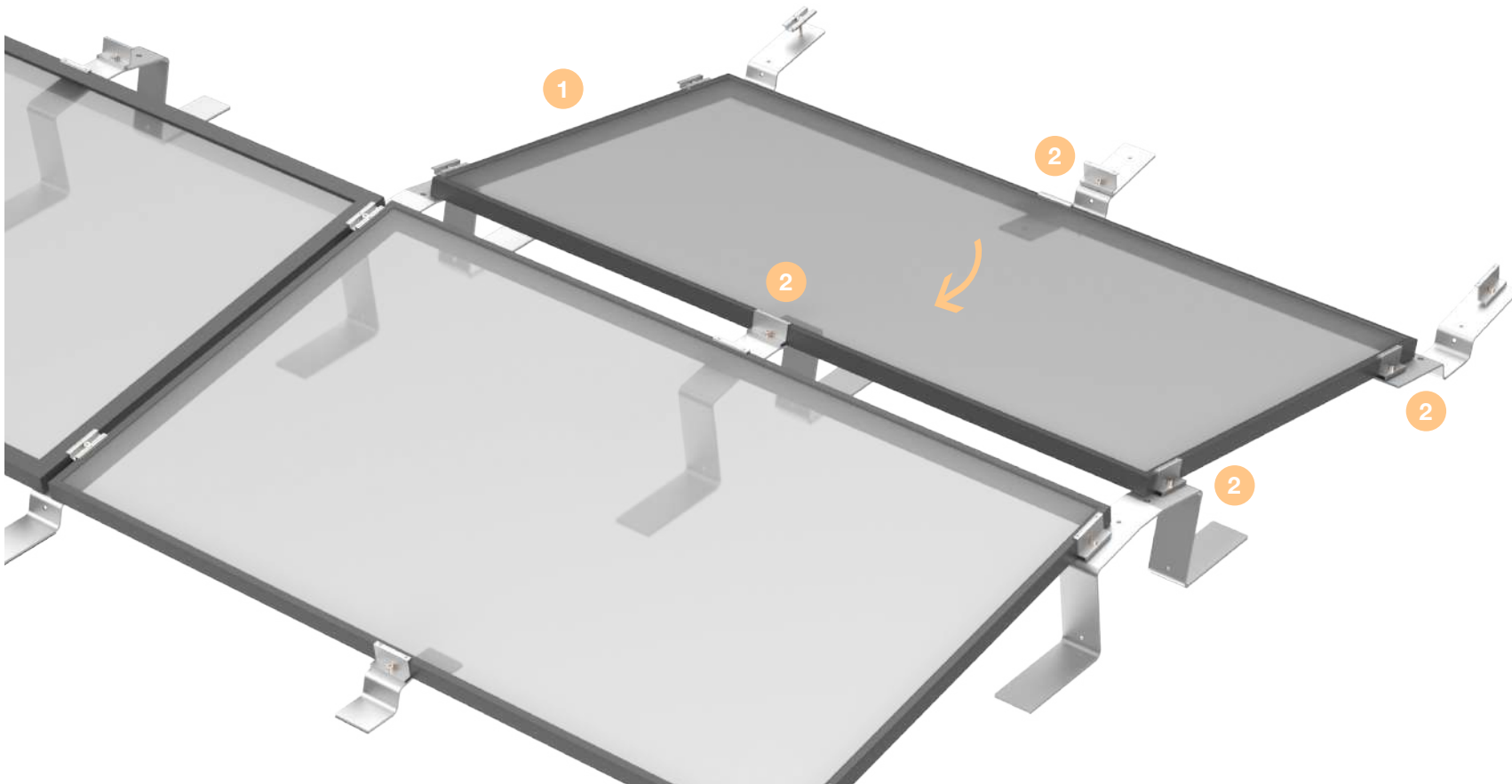

OPTIONAL: MOUNTING ALPINE SUPPORTS

MOUNTING THE MODULES

- » For a stronger bond, attach a further end clamp at the marked positions.
- » Tighten the screws to 15 Nm.
- » Mount further modules row by row as described.

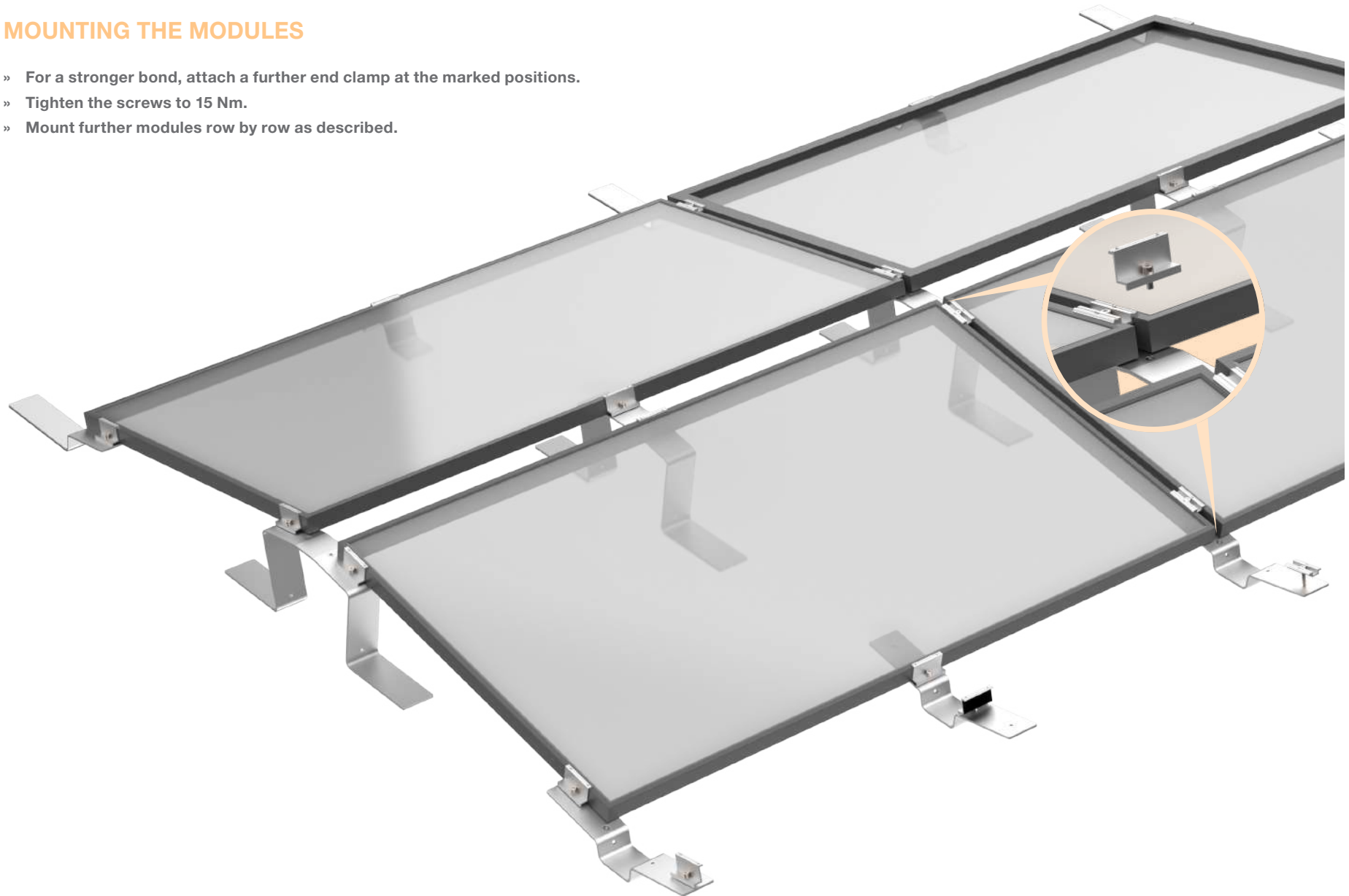

OPTIONAL: MOUNTING ALPINE SUPPORTS

MOUNTING THE MODULES

- » Position a front alpine support in the centre of the module on the first and last row of each module.
- » Make sure that the end clamps are flush with the module.
- » Tighten screws to 15 Nm.

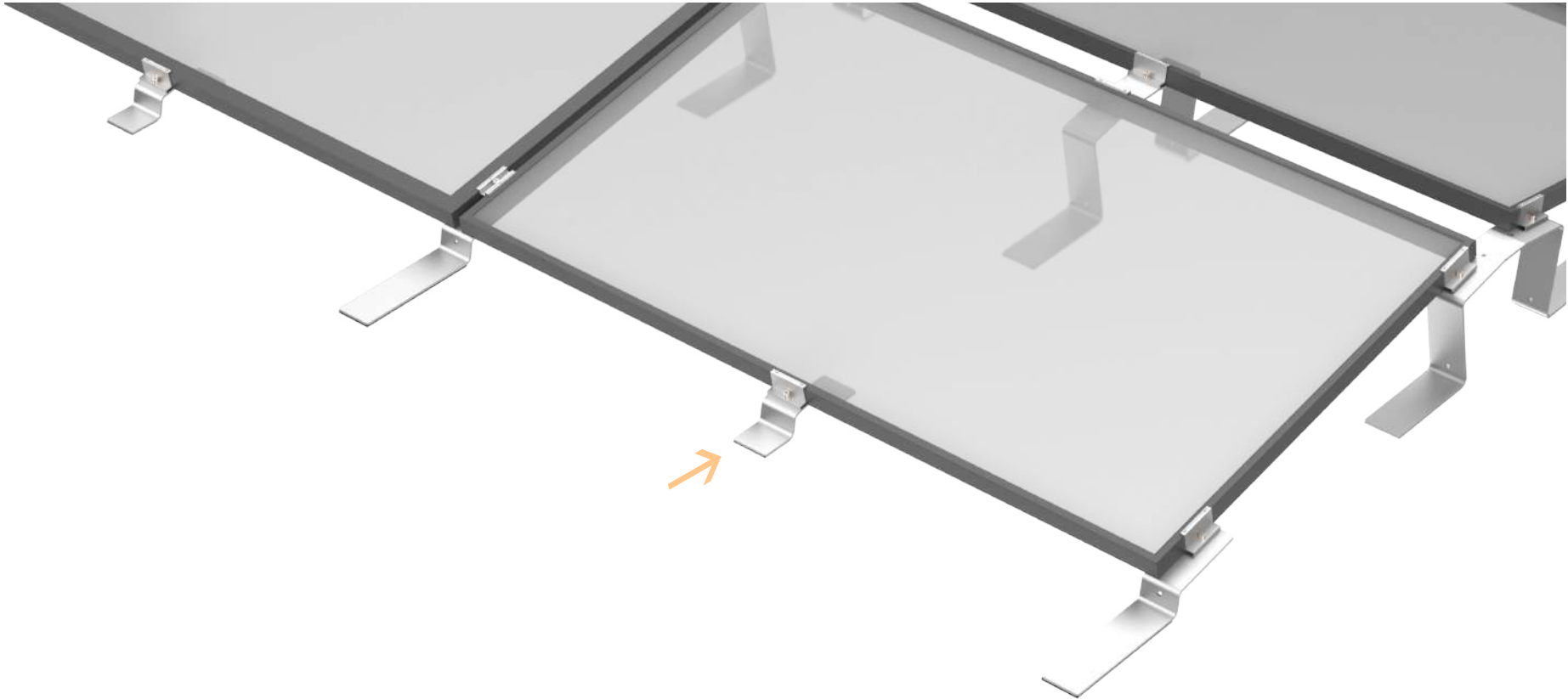

OPTIONAL: ATTACH BALLAST

| The system is ballasted differently depending on the structural conditions.

BALLAST SYSTEM ON GRAVEL ROOFS

Setting up the system on seal or protective fleece

- » **Mount ballast trays according to the plan.**
- » **Use gravel already on the roof for the ballast system in accordance with the ALUMERO.PRO.TOOL report.**
- » **Distribute the remaining gravel evenly on the roof.**
- » **Make sure there is enough gravel on the whole roof. Add more gravel if necessary.**

OPTIONAL: ATTACH BALLAST

VARIANT 1: BALLAST SYSTEM DIRECTLY ON THE START MOUNTS, MIDDLE SUPPORTS OR CONNECTORS

With this ballast variant, the ballast blocks are placed directly on the start mounts, connectors or middle supports.

The exact number and position of the ballast blocks can be found in the ALUMERO. PRO.TOOL planning documents.

Recommendation: Use a weatherproof construction adhesive to glue the building protection mats and ballast blocks.

- » Position building protection mats **1** on the right and left of the start mount, middle support or connector to compensate height difference.
- » Set the ballast block **2** in place.

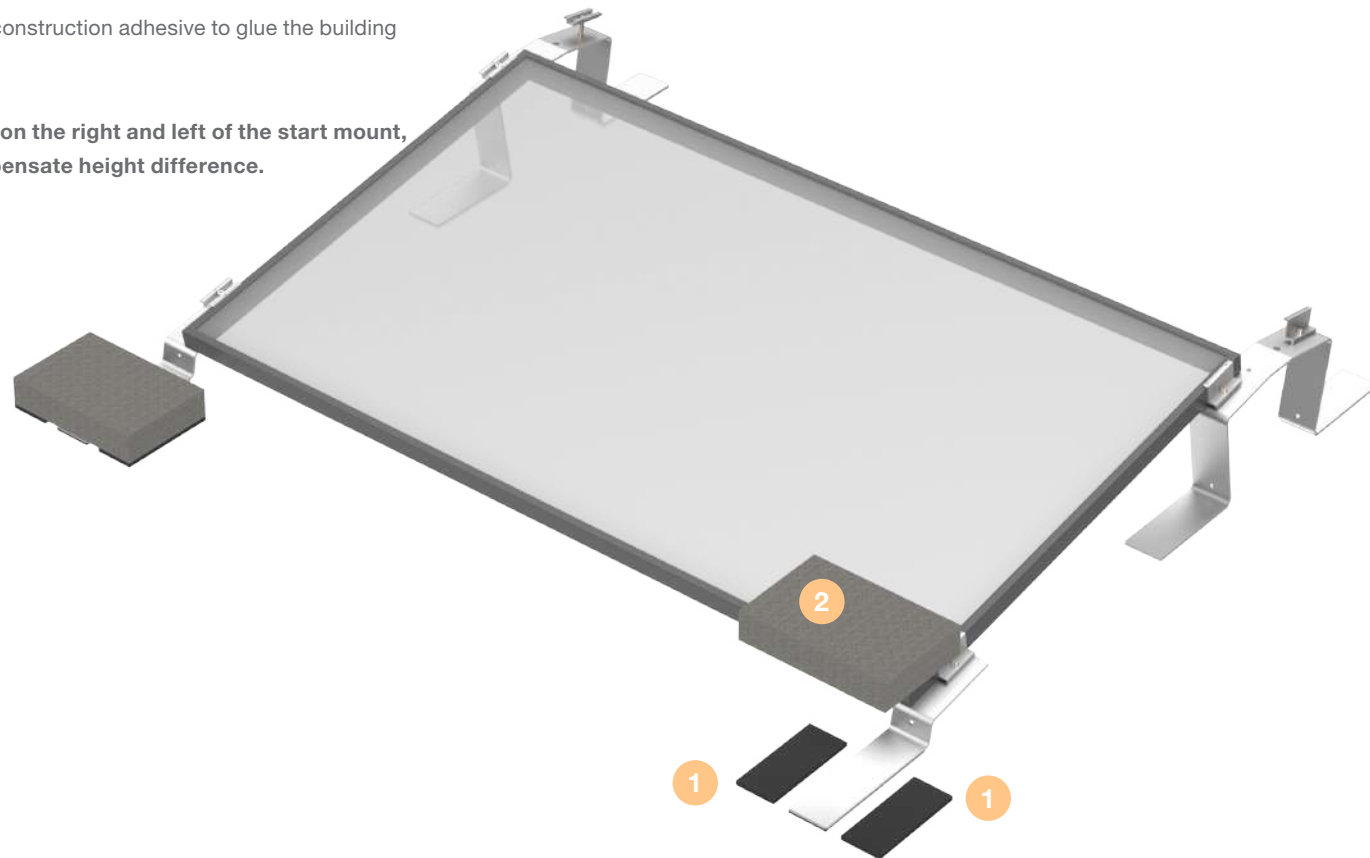

OPTIONAL: ATTACH BALLAST

VARIANT 2: SHORT BALLAST TRAY

The short ballast tray can be attached in the following positions:

- 1 on the start mount
- 2 on the middle support
- 3 on the connector
- 4 on the start mount – last row, mirrored

The exact number and position of the short ballast trays can be found in the ALUMERO.PRO.TOOL planning documents.

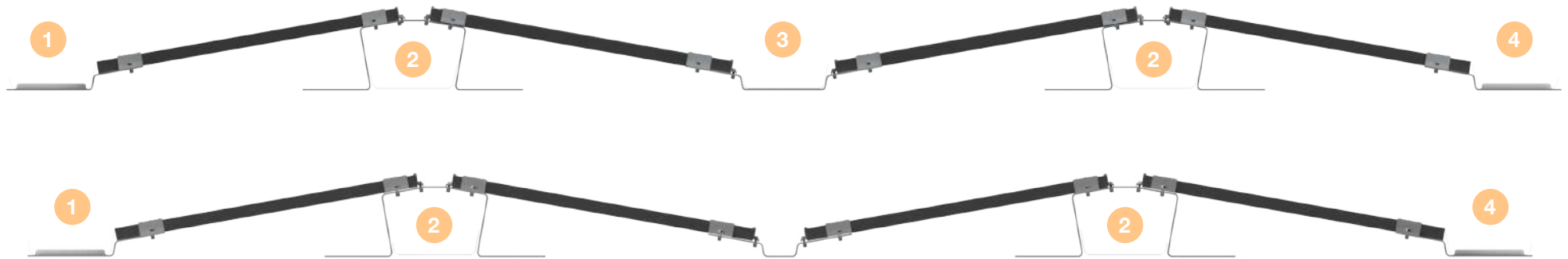

OPTIONAL: ATTACH BALLAST

VARIANT 2: SHORT BALLAST TRAY

Mounting the short ballast tray

- » Position building protection mats **1** to the left and right at the edge of the ballast tray.
- » Place ballast tray **2** centrally on the mount or connector.
- » Screw the ballast tray **3** to the mount or connector using cup square bolt, washer and hexagon nut **4**.
- » Tighten bolts to 15 Nm.

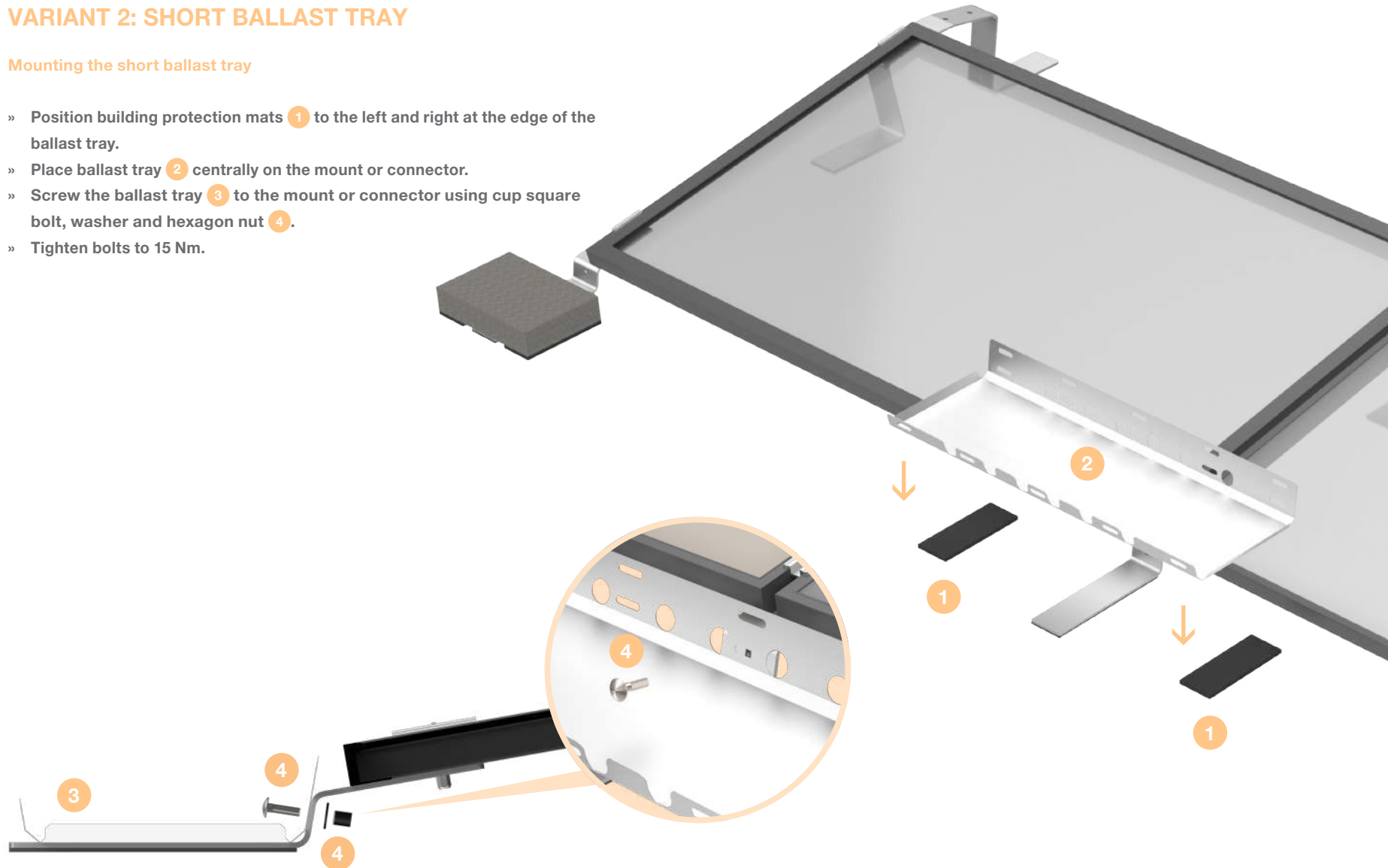

OPTIONAL: ATTACH BALLAST

VARIANT 3: LONG BALLAST TRAY

The long ballast tray can be attached in the following positions:

- 1 on the start mount
- 2 on the middle support
- 3 on the connector
- 4 on the start mount – last row, mirrored

The exact number and position of the long ballast trays can be found in the ALUMERO.PRO.TOOL planning documents.

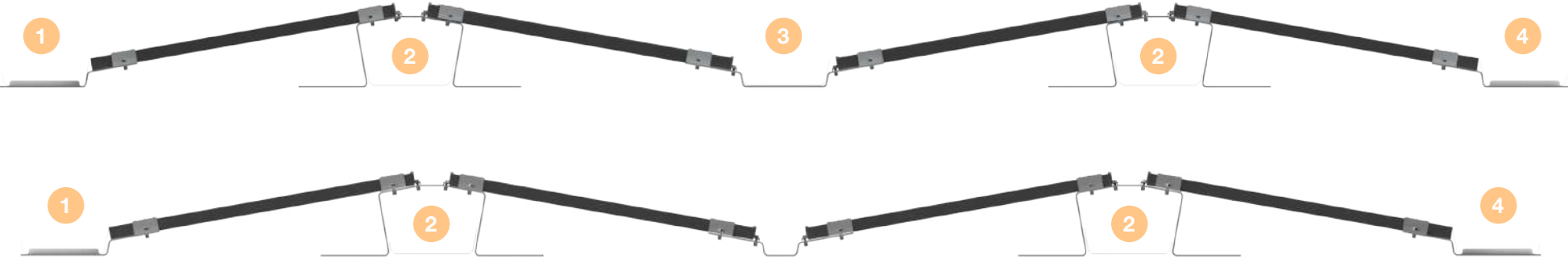

OPTIONAL: ATTACH BALLAST

VARIANT 3: LONG BALLAST TRAY

Positioning building protection mats

Depending on the length of the ballast tray, a different number of building protection mats per ballast tray is required:

Length 1800 mm: 3 building protection mats per ballast tray

Length 2050 mm: 4 building protection mats per ballast tray

Length 2300 mm: 5 building protection mats per ballast tray

When positioning the building protection mats, make sure that the drain holes are not covered.

» **Distribute the building protection mats evenly under the ballast trays.**

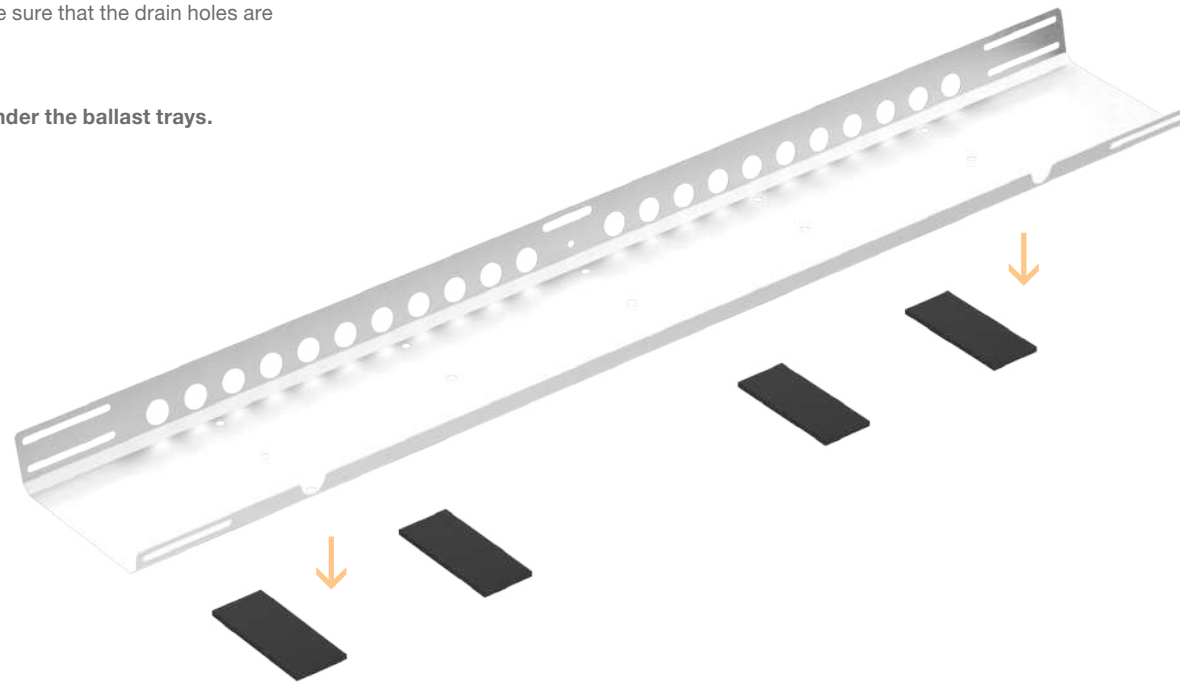

OPTIONAL: ATTACH BALLAST

VARIANT 3: LONG BALLAST TRAY

Mounting a long ballast tray on the start mount or middle support or connector

- » If several ballast trays are mounted next to one another: Design the ballast trays in such a way that they overlap at the connectors or start mounts **1**.
- » Screw the ballast tray to the supports using cup square bolt **2**.
- » Tighten bolts to 15 Nm.

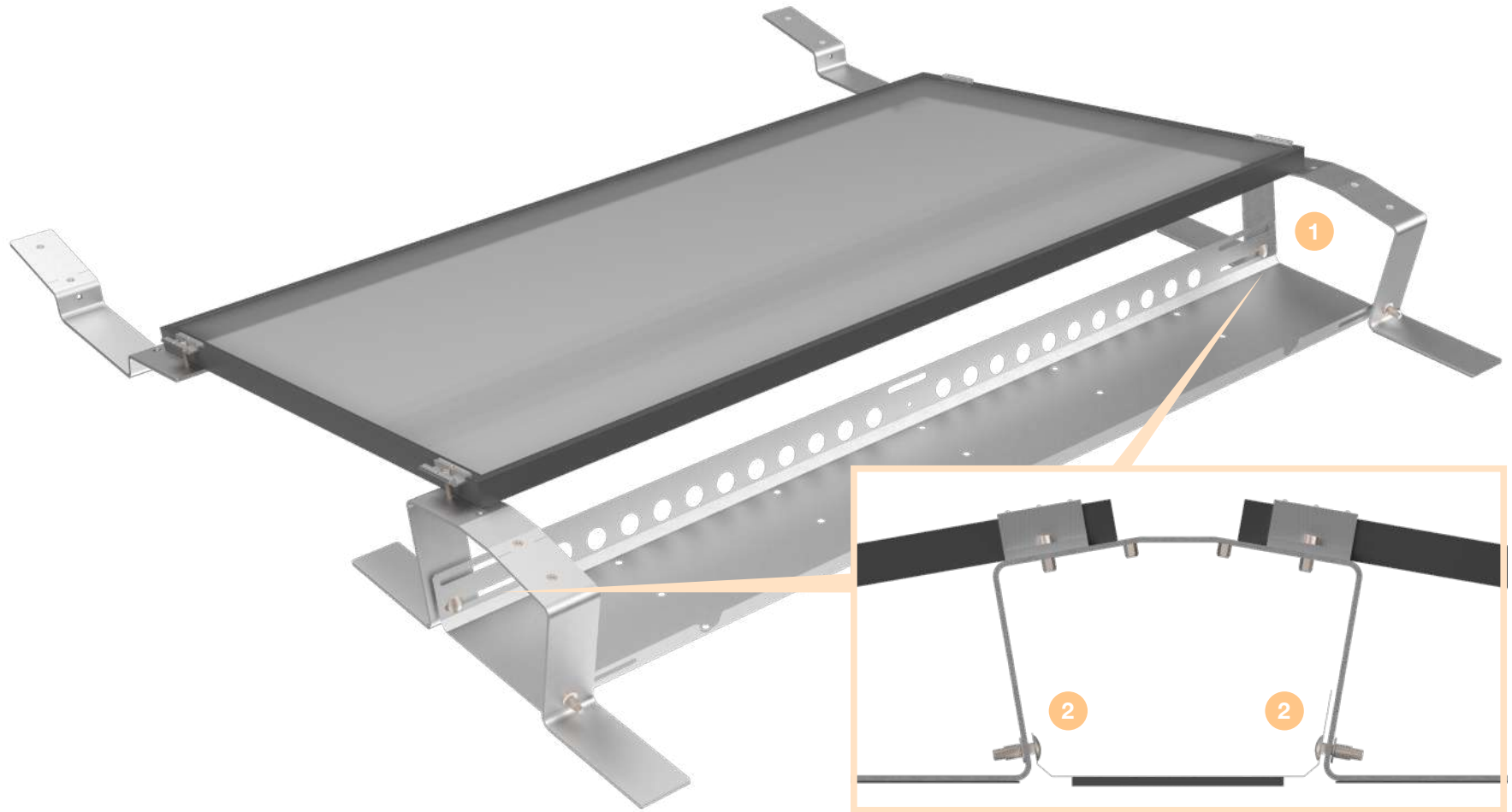

OPTIONAL: ATTACH BALLAST

VARIANT 3: LONG BALLAST TRAY

Mounting long ballast tray on the middle support

- » Place the ballast tray **1** under the middle support.
- » Screw the ballast tray to the middle supports using two cup square bolts **2**.

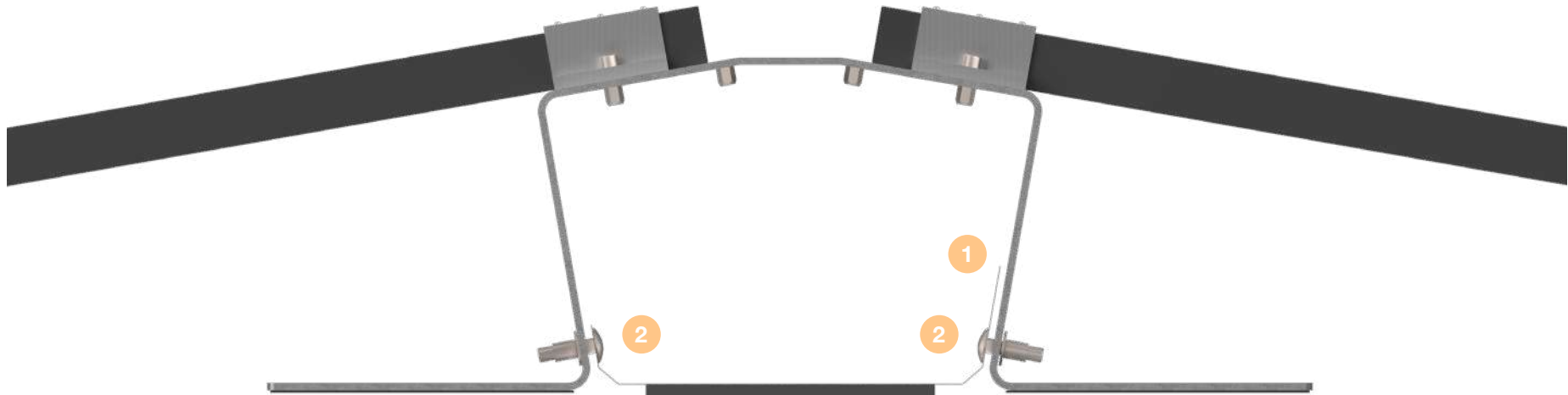

OPTIONAL: MOUNTING ROOF ANCHOR CONNECTION

MOUNTING BRACKET DIMENSIONING

The roof anchors must be provided on site and are not included in the scope of delivery. For mounting of the roof anchor connection, the on-site roof anchors must be equipped with a threaded rod max. M10 in size.

The number and positions of the roof anchors can be found in the ALUMERO.PRO.TOOL planning documents.

ALUMERO.PRO.TOOL only marks the component on which the roof anchor is mounted.

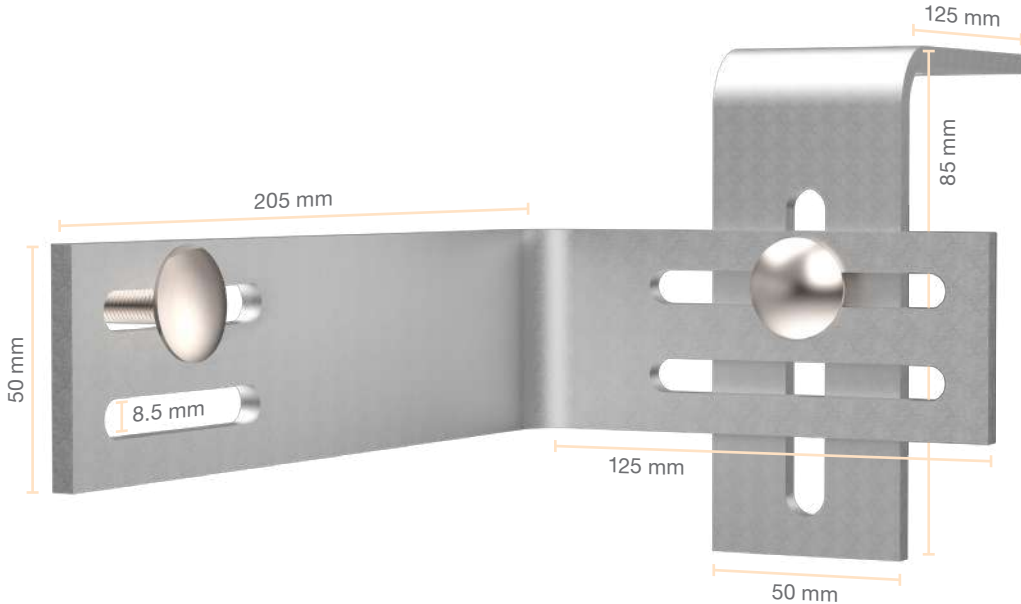

OPTIONAL: MOUNTING ROOF ANCHOR CONNECTION

CONNECTING THE SYSTEM WITH MOUNTING BRACKET

- » Position the angled connector 1 and the upright 2 flush against one another.
- » Connect the angle connector 1 and the upright 2 to one another at the slotted holes using the cup square bolts 3 and nuts 4.
- » Connect both angle connectors 1 using a cup square bolt 3, washer and hexagon nut 4.
- » Screw the angle connector 1 to the roof anchor prepared on site.
- » Tighten all the nuts 4 to 15 Nm.

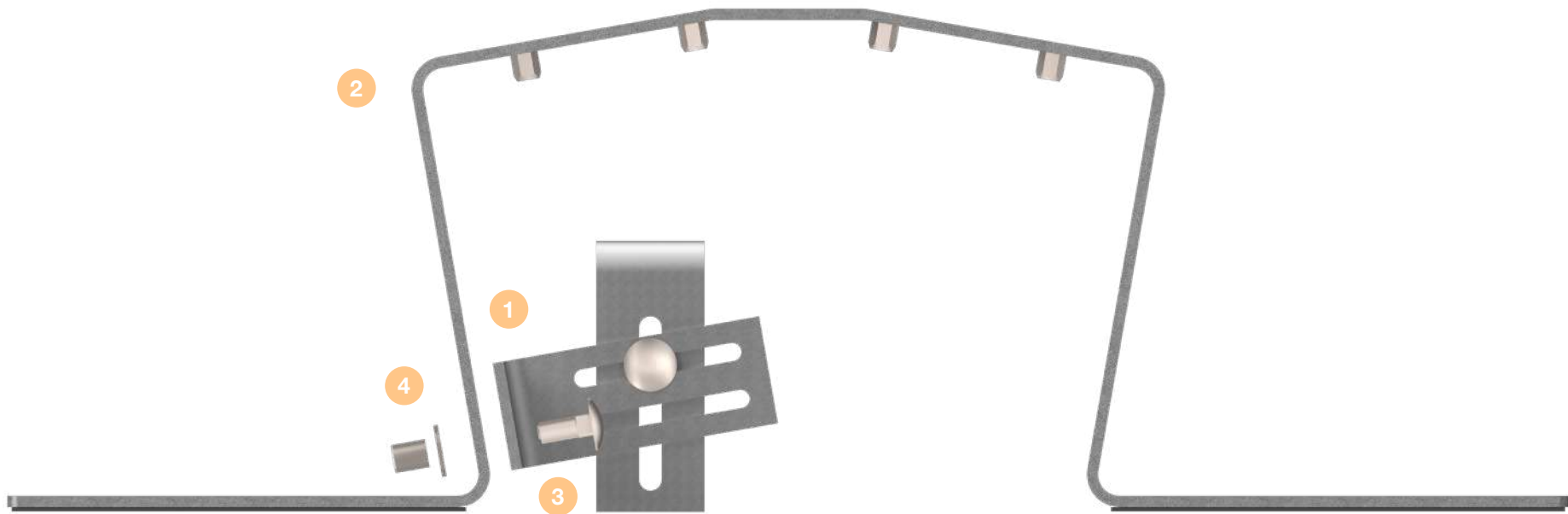
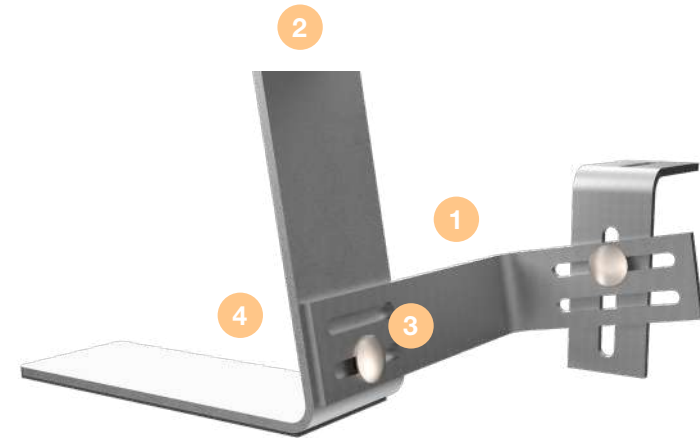

OPTIONAL: MOUNTING EARTHING / EQUIPOTENTIAL BONDING

The earthing / equipotential bonding is attached by bolt (max. M8) to a mount at the edge of a module array. The components are not included in the scope of delivery.

- » Connect the earthing wire (on site) **1** tightly to the cable lug **2**.
- » Attach the washer **3** and cable lug **2** to the bolt **4** in the order shown.

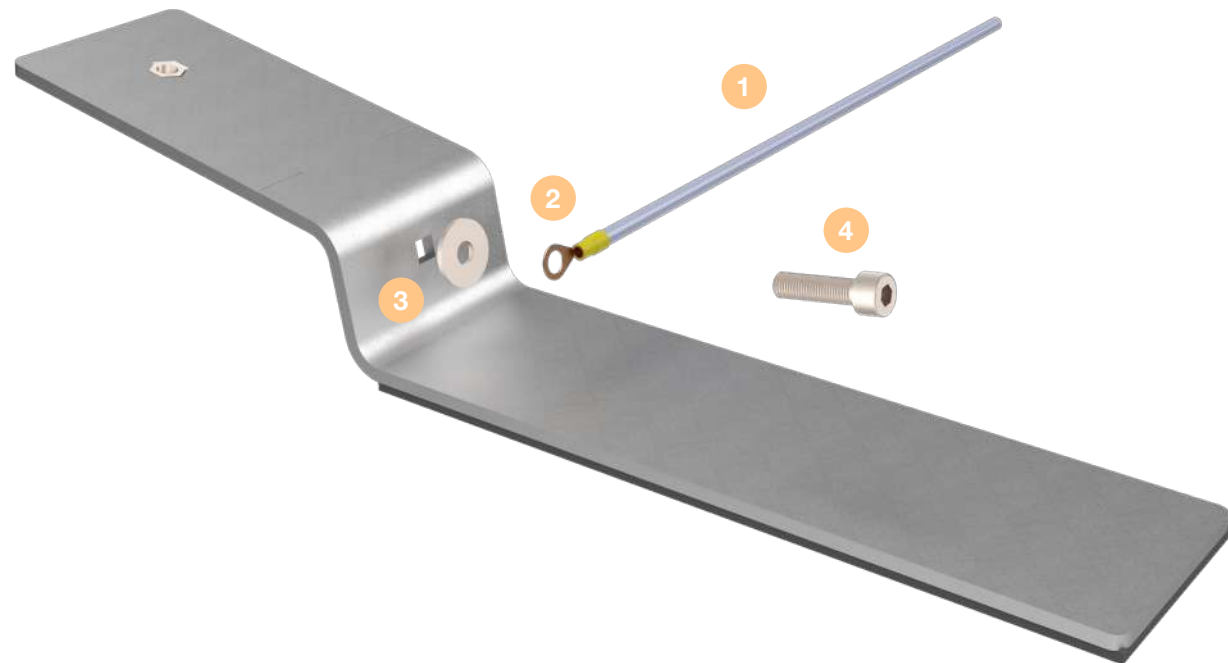

ABOUT THIS DOCUMENT

These mounting instructions describe the procedure for mounting the product. Read these mounting instructions through carefully before starting mounting. Keep to the instructions exactly in order to guarantee correct mounting of the product.

MUTUALLY APPLICABLE DOCUMENTS

The following documents are part of these mounting instructions and absolutely necessary for the correct mounting of the system:

- » **Project report from ALUMERO.PRO.TOOL**
- » **Planning documents and drawings**

TARGET GROUP

These mounting instructions address trained qualified personnel who is familiar with mounting photovoltaic systems. The qualified personnel is also familiar with working on roofs and knows the local regulations concerning work safety. The qualified personnel must also observe the instructions in the chapter about safety.

INTENDED USE

The ALUMERO flat roof AC 2.1 is exclusively designed for mounting PV modules on flat roofs or similar flat surfaces. Intended use also includes the professional mounting in accordance with these mounting instructions.

The module manufacturer must provide approval for the use of its PV modules with the ALUMERO AC 2.1 system. ALUMERO does not accept any liability for loss of performance or damage of any kind to the PV modules.

Any other use of the ALMERO AC 2.1 system is considered unintended.

LIABILITY. WARRANTY, GUARANTEE

These mounting instructions and the project report provided are integral parts of the product. The information, data and instructions provided in the mounting instructions were up to date at the time of printing. No claims can be made for products already delivered on the basis of data, illustrations and descriptions.

The project report provided includes the static calculation, which is related to the site. The position of the modules on the roof, the number and position of the building protection mats and the distribution of ballast must be carried out exactly according to the data in the project report. If the distribution of the modules on the roof changes due to local conditions e.g. unforeseen interfering surfaces, the static calculation must be prepared again. The software ALUMERO.PRO.TOOL is used for designing and planning the ALUMERO system.

ALUMERO does not accept any liability for damage and malfunctions caused by:

- » **unintended use**
- » **use of non-certified components**
- » **unauthorised modifications to the product**
- » **improper work on and with the product**
- » **mounting errors**
- » **disregarding the mounting instructions or planning documents**

GUARANTEE

The guarantee period for the system is 10 years. The guarantee period for the galvanised steel parts is 10 years. The guarantee is only granted if mounting is carried out professionally and all system components are purchased from ALUMERO. The guarantee cannot be claimed if the mounting instructions or planning documents are disregarded.

Photovoltaic mounting systems are not maintenance-free. Carry out maintenance annually as well as after unusual weather events e.g. after heavy storms or snow-fall etc. If maintenance is not carried out at the specified interval, the guarantee will be voided.

MAINTENANCE

To prevent personal injury and damage to property, the system has to be checked regularly by qualified personnel. The system operator must carry out the following maintenance points once every year.

It is also necessary to check the system after extreme weather events (e.g. storm, snow, hail etc.) as well as after an earthquake.

Complete system

- » **Check all the system components for damage.**
- » **Replace damaged components as quickly as possible.**

Threaded connections

- » **Check all threaded connections.**
- » **Tighten loose threaded connections.**
Heed the tightening torque in accordance with the mounting instructions.

GENERAL INFORMATION ABOUT LIABILITY

We would like to point out that the flat roof system is sold as part of a sales contract. Mounting / processing by the purchaser or third party is not carried out in the name or on behalf of ALUMERO Systematic Solutions GmbH. It must be carried out by qualified personnel strictly in accordance with the specifications of the mounting instructions. The software ALUMERO.PRO.TOOL must be used for designing and planning the ALUMERO system. ALUMERO Systematic Solutions GmbH is not responsible for the project-related structural design of the roof structure, for obtaining and documenting the consent of the roof manufacturer for the installation of the corresponding fasteners on the respective roof (in the sense of warranties) and for the professional execution.

Defects and damage as well as limited or insufficient functionality of the system as a result of incorrect mounting and/or mounting deviating from the mounting instructions and/or the project report (ALUMERO.PRO.TOOL) shall exclude a material defect for which ALUMERO Systematic Solutions GmbH is responsible.

In the event of improper processing, the purchaser's rights due to a material defect shall expire. The system warranty is only valid if all the system components were purchased from ALUMERO Systematic Solutions GmbH.

SYSTEMS WITH CLAMPING ON THE SHORT SIDE OF THE MODULE

In the case of a system where the clamping is on the short module side, it is assumed that the module may also be used in this mounting form (clamping on the short module sides). The approval can be given either generally as part of the module certification or may also be given project-specifically by the module manufacturer.

SYSTEMS WITH BUILDING PROTECTION MATS

The building protection mat included in the scope of delivery is matched to the roof surface defined in the project. Due to the large number of different previous and current types of waterproofing available on the market, the compatibility and the coefficient of static friction between the building protection mat and the roof structure of the building used as a basis in the system design must be ensured by the person responsible for the project.

The coefficient of friction preset in the planning program must be checked by the mounting company/purchaser (wet and dry test). If a lower coefficient of friction is determined on site, this must be entered here for the load calculation!

SAFETY

REQUIREMENTS ON PERSONNEL

The person must be at least 16 years of age and in appropriate physical and mental condition. The mounting personnel must never be under the influence of medication, alcohol or drugs. Persons who are not fit and healthy must not carry out work on roofs.

Trainee personnel may only carry out work under the instruction and supervision of skilled personnel who are authorised to train personnel.

WORK SAFETY

The company carrying out the mounting work is responsible for ensuring that local regulations on work safety and accident prevention are complied with.

BREAKTHROUGH PROTECTION

Roof windows, skylights, large ventilation flaps, etc. often cannot withstand the weight or impact of a person. Such objects must be secured in a similar way to the edge of the roof. Corrugated cement roofs can be at risk of collapse over the whole surface. Define walkways and secure them with load distribution measures.

On roofing or roof constructions with insufficient load-bearing capacity (e.g. thin sheets, corrugated fibre cement), always use load-distribution aids.

CLIMBING AIDS



Only use suitable, intact and tested ladders. Set up and secure ladders according to specifications. Separate rules apply for mechanical climbing aids (lifts, cherry pickers etc.). Never use the PV mounting system as a climbing aid.

WEATHER CONDITIONS

If the weather is unsuitable, do not work on the roof for longer than necessary or do not start work at all.

Never carry out mounting work in strong winds. Strong winds exert enormous forces, particularly on large PV modules. There is a risk of a module being torn off the roof and people being injured.

Never work in the wet or when temperatures are below freezing. There is a slipping hazard depending on the roof pitch.

HAZARDS DUE TO THE SURROUNDINGS

Keep a sufficient distance away from overhead electricity transmission lines. The following distances must be observed:



- 1 m up to 1,000 V**
- 3 m: 1,000 up to 11,000 V**
- 4 m: 11,000 up to 22,000 V**
- 5 m: 22,000 up to 38,000 V**
- > 5 m: if the voltage is unknown**

PROTECTION AGAINST FALLING OBJECTS

Areas under the roof on which work is being carried out must be protected against falling objects. Where this cannot be achieved, the area must be closed for the public.

People involved in the construction project must wear safety helmets.

PERSONAL PROTECTIVE EQUIPMENT (PPE)

Personal protective equipment is required to protect against injuries during mounting work.

- » **Wear safety goggles during drilling.**
- » **Wear safety footwear.**
- » **Wear cut-resistant work gloves during mounting.**
- » **All those involved in the construction site must wear a helmet.**
- » **Use fall protection.**

IMPRINT

We reserve the right to make changes due to technical improvements! These mounting instructions correspond to the technical status of the delivered product and not to the current development status at the manufacturer.

If any pages or parts of the mounting instructions are missing, please contact the manufacturer at the address given below.

The original language of these mounting instructions is German. Any mounting instructions in another language is a translation of the mounting instructions in German.

MANUFACTURER

ALUMERO Systematic Solutions GmbH
Sonnenweg 1-2
5162 Seeham - Austria
T +436217 / 68 41 - 0
F +436217 / 68 41 - 41
alumero@alumero.at
www.alumerogroup.eu

UPDATE

These instructions can be modified without prior notice. This does not represent any obligation on the part of the manufacturer.

DATE CREATED

03.2023

ALUMERO

CONGRATULATIONS,
WELL DONE!

CONTACT HEADQUARTERS

ALUMERO Systematic Solutions GmbH
Sonnenweg 1-2
5162 Seeham - Austria

T +436217 / 68 41 - 0
F +436217 / 68 41 - 41
alumero@alumero.at
www.alumerogroup.eu